

## ~ Assembly Manual ~

# Micro908 *Antenna Analyst*



*The Micro908 is a flexible and re-usable control platform for ham radio projects. The Micro908 platform is designed to be easily operated on the bench as well as in the field. It is comprised of a single 5" x 5" printed circuit board containing all components, connectors, controls, LCD, and two daughtercards. The plastic enclosure contains an 8-cell AA battery back enabling convenient field use. A number of standard ham radio peripherals may be connected to the Micro908: antenna, paddles, a PC-style keyboard, headphones, an audio line to drive an SSB transceiver, a keyline to drive a transmitter, your rig's audio in/out signals, and custom control lines via an auxiliary jack. The first major software available for the Micro908 platform is the **Antenna Analyst** – an instrument that automatically determines SWR and complex impedance characteristics of an HF antenna system. Advanced features of DDS frequency control, LCD tuning, PC data collection and plotting, numerous operating modes and easy software upgradability make this instrument attractive for homebrewers and antenna enthusiasts.*

# CONTENTS

<b>Section 1:</b>	Introduction .....	2
<b>Section 2:</b>	Parts Inventory .....	3
<b>Section 3:</b>	PCB Preparation .....	8
<b>Section 4:</b>	Installing the Surface Mount Components .....	10
<b>Section 5:</b>	Installing the Controls and Connectors.....	15
<b>Section 6:</b>	Power-up and Test .....	20
<b>Section 7:</b>	Installing the PC Board in the Enclosure.....	21
<b>Section 8:</b>	Troubleshooting .....	23
<b>Appendix A:</b>	Parts List .....	26
<b>Appendix B:</b>	Schematic .....	29
<b>Appendix C:</b>	Component Layout .....	31
<b>Appendix D:</b>	Fully-Assembled PC Board .....	33
<b>Appendix E:</b>	Mechanical Assembly Diagram .....	34
<b>Appendix F:</b>	Quick Reference Sheet .....	35
<b>Appendix G:</b>	Loading New Software into the Micro908 .....	36
<b>Appendix H:</b>	Making a Dummy Antenna for Testing .....	37

---

## Section 1: Introduction

Welcome to the Micro908 Antenna Analyst Kit, a reprogrammable and multi-use microcontrolled instrument that will provide years of reliable service in both the shack and the field when constructed according to this assembly guide.

This project involves the soldering of small surface mount technology (SMT) parts and other delicate components to a printed circuit card, and it will take about six hours to assemble – perhaps several evenings or over a weekend. Once the kit is assembled, the pre-programmed controller (the HC908 Daughtercard) may be inserted into place and immediate indication of product operation will be seen.

This Assembly Manual provides detailed, step-by-step instructions on preparation of the components, installation of them to the printed circuit board and enclosure, and basic calibration and operation of the instrument. Other documents provided on the enclosed CDROM describe the technical overview and more detailed usage. Several useful software programs are also contained on this Micro908 Resource CDROM, such as a software loader application and a terminal program. Additionally, the CD contains information and full software source code that will be useful for those wishing to develop custom software for the Micro908 platform.

Please regularly visit the Micro908 project website ([www.amqrp.org/kits/micro908](http://www.amqrp.org/kits/micro908)) to download updated versions of the software, manuals and schematics. We are also maintaining a list of frequently asked questions (and answers) that will surely be of help to you in building and using this kit. An even more complete and up to date Assembly Manual, with additional photos (all in color) may be found at the Micro908 online site.

We've made every effort possible within reason to make construction and use of the Micro908 Antenna Analyst a success for the builder. Please let us know how it works out for you or if you have any questions along the way. We thank you for purchasing the Micro908 Kit from the AmQRP Club and we wish you good luck in building and using it!

**Sincerely yours,**

“The Micro908 Team”

George Heron, N2APB [n2apb@amqrp.org](mailto:n2apb@amqrp.org)

Joe Ev erhart, N2CX [n2cx@amqrp.org](mailto:n2cx@amqrp.org)

Tom (W8KOX) & Nancy (NJ8B) Feeny, [w8kox@amqrp.org](mailto:w8kox@amqrp.org)

David Willmore, N0YMV, [willmore@optonline.net](mailto:willmore@optonline.net)

## Section 2: Parts Inventory

Carefully review the contents of each parts bag and component supplied in the kit to ensure that you have everything needed at the start of the project. If a part is missing, please contact us by email and we'll get it out to you right away.

### Surface Mount Components Sheet

Resistor Card 1		
QTY	Designator	Description
1	R46	Resistor, 10, SMT, 1206
3	R11, R12, R14	Resistor, 49.9, SMT, 1206, 1%
1	R7	Resistor, 330, SMT, 1206
1	R8	Resistor, 1K, SMT, 1206
1	R6	Resistor, 4.3K, SMT, 1206
1	R44	Resistor, 4.7K, SMT, 1206
4	R37, R38, R39, R40	Resistor, 5.1K, SMT, 1206
12	R1, R2, R3, R4, R5, R17, R18, R22, R23, R27, R42, R48	Resistor, 10K, SMT, 1206
1	R41	Resistor, 10.0K, SMT, 1206, 1%

Resistor Card 2		
QTY	Designator	Description
1	R1 (DDS card)	Resistor, 12.1K, SMT, 1206, 1%
1	R28	Resistor, 22K, SMT, 1206, 1%
4	R10, R13, R15, R49	Resistor, 47K, SMT, 1206
4	R19, R24, R29, R51	Resistor, 71.5K, SMT, 1206, 1%
4	R16, R21, R26, R50	Resistor, 220K, SMT, 1206
3	R20, R30, R52	Resistor, 221K, SMT, 1206, 1%
1	R25	Resistor, 549K, SMT, 1206, 1%
4	R32, R33, R34, R54	Resistor, 1M, SMT, 1206

Capacitors & Semiconductors		
QTY	Designator	Description
4	C17, C19, C21, 41	Capacitor, 220 pF, SMT, 1206
2	C31, C32	Capacitor, 560 pF, SMT, 1206
7	C18, C20, C22, C23, C28, C40, C42	Capacitor, 0.01 uF, SMT, 1206
16	C1, C2, C3, C4, C6, C11, C12, C13, C14, C15, C25, C35, C36, C37, C38, C39	Capacitor, 0.1 uF, SMT, 1206
2	C29, C30	Capacitor, 0.33 uF, SMT, 1206
1	U6	IC, Level Translator, TC7SET08F
10	D1, D2, D3, D4, D5, D6, D10, D11, D12, D13	Diode, Schottky, 1N5711, SMT

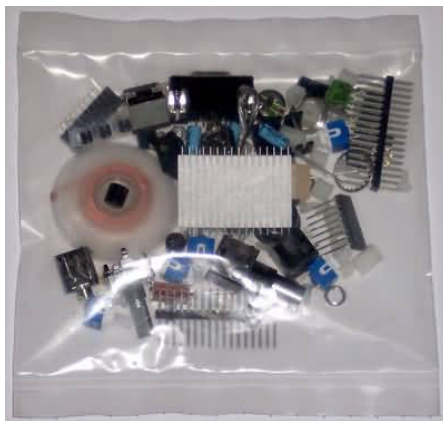

### Controls & Connectors Bag

1	J1	BNC, pcb mount
1	J2	Serial port connector, DB9F
1	ENC	Rotary Encoder
1	J4	Coaxial power connector, 2.1mm
1	J8	Socket, 1x12 pos'n (DSP out)
1	J9	Socket, 2x10 position, (DSP in)
1	J11	Mini-DIN, 6 pos'n (KBD)
3	J6, J7, J12	Audio jack, 1/8", pcb mount
1	J10	Socket, 1x8 pos'n, right angle
1	J14	Mini-Din, 8 pos'n (AUX)
1	W1	Jumper, Flexstrip, (LCD)
2	P1, P2	Pinheader, 2x34 (HC908) (cut 2 from 2x72 strip)
2	P3, P4	Pinheader, 1x2 pos'n (MON) (cut from 2x72 strip)
3	C7, C33, C34	Capacitor, 1 uF, Electrolytic, SMT
2	C5, C26	Capacitor, 10 uF, Electrolytic
1	C27	Capacitor, 47 uF, Electrolytic
1	C24	Capacitor, 100 uF, Electrolytic
1	R45	Potentiometer, 10K, miniature, pcb mount
1	S2	Slide switch, pcb mount, SPST
5	PB1, PB2, PB3, PB4, PB5	Pushbuttons, SPST, momentary contact
1	SPKR	Speaker, miniature, 32-ohm
5		Pushbutton caps (black)
1		Heatsink - TO220
1		Knob, 1/4"-dia shaft, (ENC)
1		Nut, zinc plated, 4-40 (U1)
1		Machine screw, zinc plated, round head, 4-40 x 0.5" (U1)
4		Spacer, nylon, hex tapped, 4-40x0.25" (LCD)
6		Spacer, nylon, hex tapped, 4-40x0.375" (PCB+DDS)
16		Machine screw, pan slotted, #4-40x0.25" (PCB+DDS+LCD)
4		Machine screw, flat slotted, #4-40x0.25" (PCB-cover)
1		Desoldering Braid
1		Solder, 63/37 Eutectic, No-Clean Flux, @28 ga.



### Overlay Bag (Included with Enclosure Option)

1	Front panel overlay	
1	Side panel overlay	
1	End panel overlay	
1	End panel (drilled)	
1	End panel (undrilled)	
4	Enclosure screw s	
4	Enclosure rubber feet	



### Battery Holder Bag

1	LCD	Display, LCD, Hantronix, 16x2 STN, GRAY
1	J3	Battery holder, 8-AA cells
1		Flux Pen, No-Clean



Semiconductor Bag		
1	U1	Voltage regulator, 3-terminal, 7805
1	U2	Memory, SEEPROM, 512Mb
2	U3, U4	IC, Op Amp, LMC6484, SOIC
1	U5	IC, Audio Amp, LM386, SOIC
1	U6	IC, Level Translator, TC7SET08F, SOIC
1	LED1	LED, T1-3/4 (BUSY)
2	Shunt	shunt, 0.1", 2 pos'n
3	D7, D8, D9	Diode, Schottky, 1N5817, DO-41
1	VR1 - DDS Option	Voltage Regulator, 78L08, 8V (optional, for use w ith regarg
1	Q1	Transistor, NPN, 2N3904, TO92

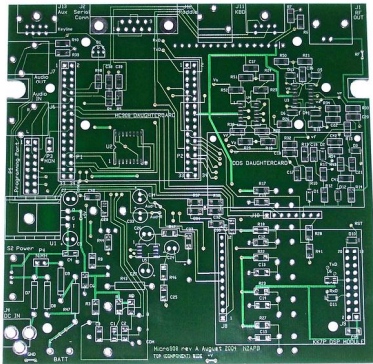

PCB Bag		
1	PCB	PC Board



HC908 Daughtercard Bag (Optional)		
1	HC908	HC908 Daughtercard assembly



**DSPx Daughtercard Bag (Optional)**

1	DSPx	DSPx for Micro908 assembly
---	------	----------------------------



**DDS Daughtercard Kit Bag (Optional)**

1	DDS Kit	DDS Daughtercard Kit
---	---------	----------------------



**Keyboard Cable Bag (Optional)**

1	Cable	Keyboard extension cable (6')
---	-------	-------------------------------



**Keyboard (Optional)**

1	Keyboard	Dauphin Mini Keyboard
---	----------	-----------------------



**Enclosure (Optional)**

1	Enclosure	Pac-Tec LH-57 Enclosure (pre-drilled)
---	-----------	---------------------------------------

### Section 3: PC Board Preparation

Meet the Micro908 PC Board! You should become familiar with the orientation nomenclature that we'll be using throughout this manual.

#### Top, "Component" Side

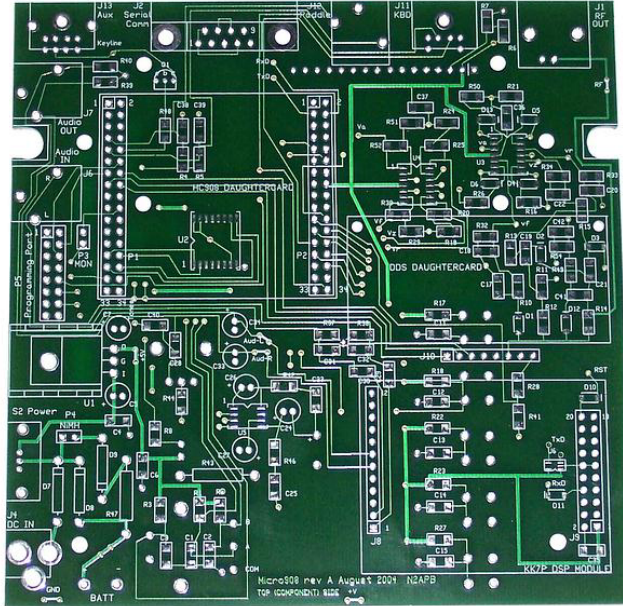

← Left

Right →

#### Bottom, "Ground", "Controls" Side

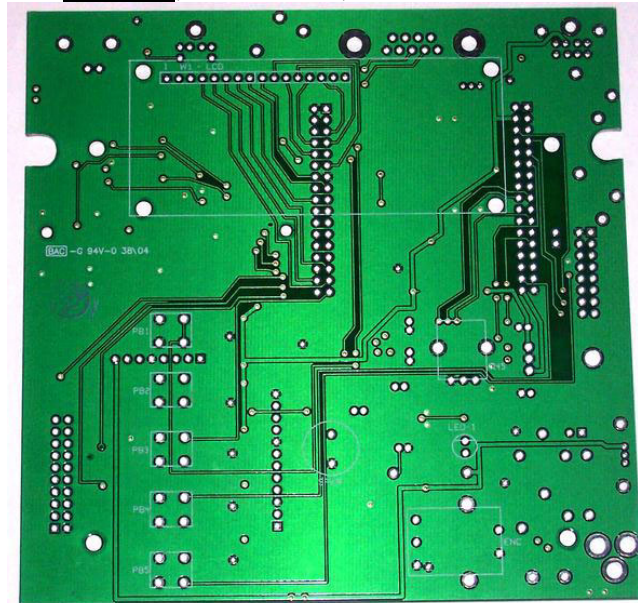

← Left

Right →

## Section 4: Installing the Surface Mount Components

### Preparing for the job

The key to being successful with any construction project is selecting and using the proper tools. For projects using SMT (Surface Mount Technology), the tools are easy to find. A magnifying lamp is essential for well-lighted, close-up work on the components. Tweezers or fine-tipped pliers allow you to grab the small chip components with dexterity. Thinner solder (.015") than you might normally use is preferred because of its being quicker to melt and smaller in solder volume on the component lead. Use of a super fine-tipped soldering iron make soldering the leads of these small parts straightforward and easy. A clean work surface is of paramount importance because SMT components often have a tendency to fly away even when held with the utmost care in tweezers – you'll have the best chance of recovering your wayward part if your table is clear. When the inevitable happens, despite your best efforts of holding an SMT part in your tweezers, you'll have lots of trouble finding it if it falls onto a rug-covered floor covered. It's best to have your work area in a non-carpeted room, for this reason as well as to protect static-sensitive parts.

### Attaching SMT Components to the PC Board

We've supplied two items in this Micro908 Kit that will greatly help you successfully solder these small surface mount components to the pc board. The first is a small coil of **.015" solder**. As described above, this thin solder is perfect for soldering small SMT parts. Just wrap the solder around a convenient tube as shown below on the left) so you can easily play out the solder as you go along in the board assembly. The other helpful item is the **Flux Pen**. By making the pads to be soldered wet with the liquid flux, you are greatly helping the joint be clean and ready to accept the soldered component. (Just press down a little on the tip of the flux pen and the liquid flux will start flowing out through the sponge tip.) In order to solder these small components in place, having a fine-tipped, 600-700 degree soldering iron is essential, as illustrated in the rightmost photo below.

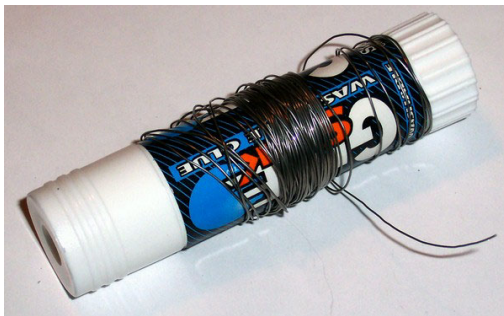

Thin solder (.015") is coiled around a glue stick.

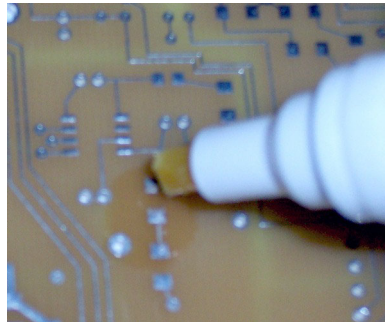

Flux pen applies flux to pads.

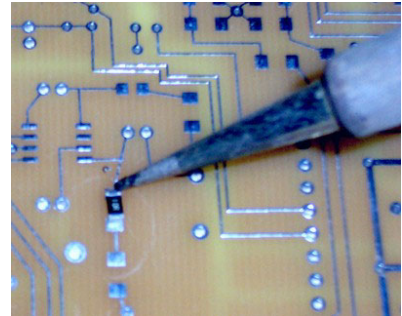

Fine tipped iron solders in SMT resistor.

The trick to soldering surface mount devices to pc boards is to (a) pre-solder one of the pads on the board where the component will ultimately go; (b) hold the component in place with needle nose pliers or tweezers on the tinned pad; (c) re-heat the tinned pad and component to reflow the solder onto the component lead, thus holding the component in place; and lastly (d) solder the other end of the component to its pad.

### Attaching a Surface Mount IC

There are four surface mount integrated circuits to attach on the Micro908 pc board: U2 (memory chip), U3 & U4 (op amps), U5 (audio amp) and U6 (a pretty tiny driver IC). Pre-solder the pad in one corner of the given layout then carefully position the leads of the IC over its set of pads on the pc board. I generally use my fingers to carefully align the IC over all its pads and then reheat the corner pad to reflow the solder onto the IC pin. This should leave the IC attached by that pin. Again making sure the IC pins are aligned over all pads, carefully solder the opposite corner lead to its pad. This should leave all other pins of the IC aligned over their respective pads, making it easier to solder them. Next solder each of the other pins to their respective pads, being careful not to bridge solder across any adjacent pads or pins. If this does happen, that's okay! Just grab some **solder wick** (also supplied in the Micro908 Kit) and use it to draw off the excess solder, which should be fairly easy and clean because of the solder mask on the circuit board.

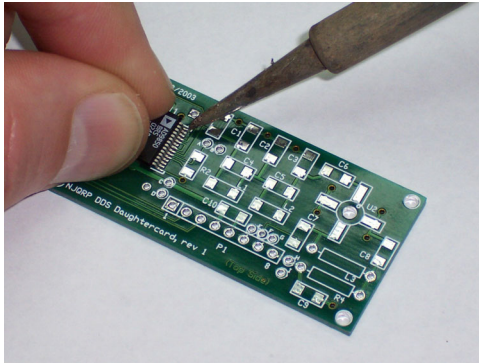

First corner pin of surface mount IC being attached.

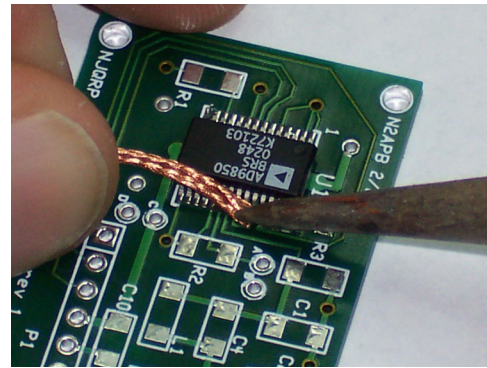

Solder wick easily absorbs excess solder between pins.

(IC shown being attached here is the DDS chip onto the DDS Daughtercard. The techniques are the same for the Micro908 ICs.)

### Using the Component Layouts During Assembly

A helpful practice to develop is to mark the supplied Layout diagram as you install each component. As you go along, the diagram will fill up with more and more marks, enabling you to more easily find the location of the remaining components, and have confidence that you haven't omitted installation of a component along the way.

A useful marking technique is to identify with a "dot" the location of the parts you are about to install, making it easier for you to place and solder the part in the right spot. Once soldered in place, going back to the diagram and placing a full line in that same spot will indicate that you've soldered it in place, as shown in the photo on the right.

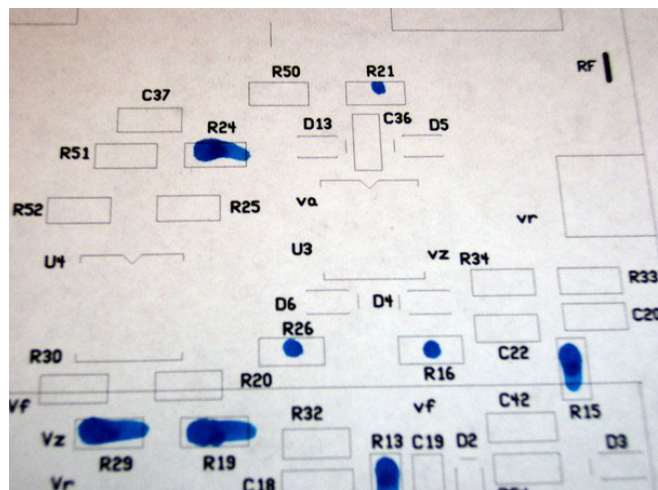
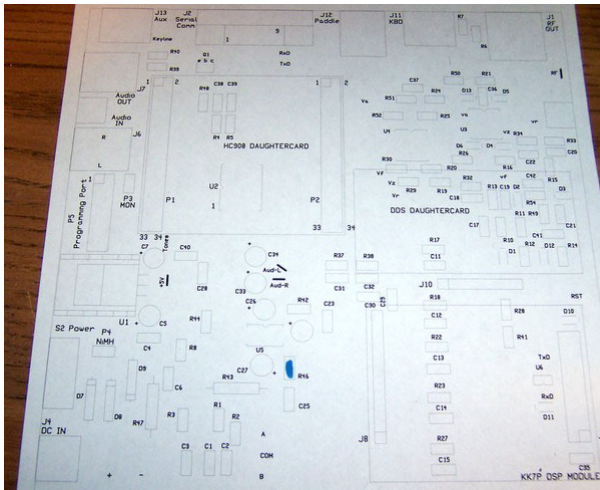

The component layout diagram is a useful tool if you mark it up as you proceed along in installing the components.

### 1) Install components from Resistor Card 1 section of the SMT Sheet

Using the Component Layout Diagram in Appendix A as a guide, install the SMT components from the Resistor Card 1. Check off each row as you complete installing those components.

#### QTY

[ ]	1	R46	Resistor, 10, SMT, 1206
[ ]	3	R11, R12, R14	Resistor, 49.9, SMT, 1206, 1%
[ ]	1	R7	Resistor, 330, SMT, 1206
[ ]	1	R8	Resistor, 1K, SMT, 1206
[ ]	1	R6	Resistor, 4.3K, SMT, 1206
[ ]	1	R44	Resistor, 4.7K, SMT, 1206

- | 4     **R37, R38, R39, R40**     **Resistor, 5.1K, SMT, 1206**
- | 12    **R1, R2, R3, R4, R5, R17, R18, R22, R23, R27, R42, R48**     **Resistor, 10K, SMT, 1206**

## 2) Install components from Resistor Card 2

Using the Component Layout Diagram in Appendix A as a guide, install the SMT components from the Resistor Card 2. Check off each row as you complete installing those components.

- | <b>QTY</b>                   |                           |                                       |
|------------------------------|---------------------------|---------------------------------------|
| <input type="checkbox"/>   1 | <b>R41</b>                | <b>Resistor, 10.0K, SMT, 1206, 1%</b> |
| <input type="checkbox"/>   1 | <b>R28</b>                | <b>Resistor, 22K, SMT, 1206, 1%</b>   |
| <input type="checkbox"/>   4 | <b>R10, R13, R15, R49</b> | <b>Resistor, 47K, SMT, 1206</b>       |
| <input type="checkbox"/>   4 | <b>R19, R24, R29, R51</b> | <b>Resistor, 71.5K, SMT, 1206, 1%</b> |
| <input type="checkbox"/>   4 | <b>R16, R21, R26, R50</b> | <b>Resistor, 220K, SMT, 1206, 1%</b>  |
| <input type="checkbox"/>   3 | <b>R20, R30, 52</b>       | <b>Resistor, 221K, SMT, 1206, 1%</b>  |
| <input type="checkbox"/>   1 | <b>R25</b>                | <b>Resistor, 549K, SMT, 1206, 1%</b>  |
| <input type="checkbox"/>   4 | <b>R32, R33, R34, R54</b> | <b>Resistor, 1M, SMT, 1206</b>        |

## 3) Install components from Capacitor & Diode Card

Using the Component Layout Diagram in Appendix A as a guide, install the SMT components from the Capacitor & Diode card. Check off each row as you complete installing those components. Be careful to identify the cathode of the diodes on this card. The cathode is the side of the diode with a single straight line on the schematic symbol, and with a (faint) single straight line on the package. You will surely need to use your magnifying glass to see this mark. Orient the end of the diode with the single straight line onto the pc board with the diode outline also containing the straight line indicating the cathode.

- |                               |  |  |
|-------------------------------|--|--|
| <input type="checkbox"/>   4  | <b>C17, C19, C21, C41</b>  | <b>Capacitor, 220 pF, SMT, 1206</b>  |
| <input type="checkbox"/>   2  | <b>C31, C32</b>  | <b>Capacitor, 560 pF, SMT, 1206</b>  |
| <input type="checkbox"/>   7  | <b>C18, C20, C22, C23, C28, C40, C42</b>   | <b>Capacitor, 0.01 uF, SMT, 1206</b>   |
| <input type="checkbox"/>   16 | <b>C1, C2, C3, C4, C6, C11, C12, C13, C14, C15, C25, C35, C36, C37, C38, C39</b> | <b>Capacitor, 0.1 uF, SMT, 1206</b>  |
| <input type="checkbox"/>   2  | <b>C29, C30</b>  | <b>Capacitor, 0.33 uF, SMT, 1206</b>   |
| <input type="checkbox"/>   10 | <b>D1, D2, D3, D4, D5, D6, D10, D11, D12, D13</b>                                | <b>Diode, Schottky, 1N5711, SMT (These diodes have faint cathode markings)</b> |

For now, don't install this leftover part on the SMT sheet. But don't lose it! (We just wanted to mention this up front!)

- |                              |           |  |
|------------------------------|-----------|--|
| <input type="checkbox"/>   1 | <b>U6</b> | <b>Integrated Circuit, Level Translator, TC7SET08F</b> |
|------------------------------|-----------|--|

## 5) Install components from Semiconductor Bag

Using the Component Layout Diagram in Appendix A as a guide, install the components from the Semiconductor Bag. Check off each row as you complete installing those components.

### QTY

- [ ] 1 U1 Voltage regulator, 3-terminal, 7805  
[ ] 1 Heatsink - TO220 (From Controls Bag)

Position the voltage regulator over the mounting hole to determine where to bend the three leads so they can be inserted to the pc board as shown below. Before soldering in place, orient the heatsink as shown and use the metal screw & nut to connect the two components to the pc board. Then, when aligned nice and straight, solder the three leads of U1 to the pads.

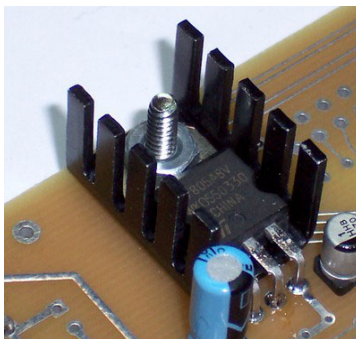

- [ ] 1 U2 Memory, SEEPROM, 512Kb (16-pin surface mount IC.)  
[ ] 2 U3, U4 IC, Op Amp, LMC6484, SOIC (14-pin surface mount IC packages.)  
[ ] 1 U5 IC, Audio Amp, LM386, SOIC (8-pin surface mount IC.)  
[ ] 1 U6 IC, Level Translator, TC7SET08F, SOIC (Very small 5-lead surface mount IC.) (This is the leftover component from the SMT sheet.)  
[ ] 3 D7, D8, D9 Diode, Schottky, 1N5817  
[ ] 1 Q1 Transistor, NPN, 2N3904, TO92 (Familiar 3-lead thru-hole package.)

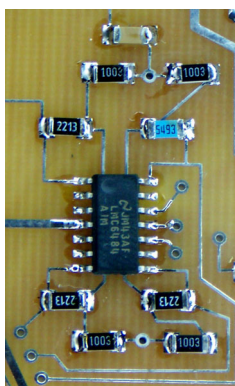

U4 op amp



U6 translator

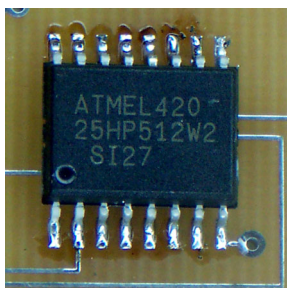

U2 SEEPROM Memory

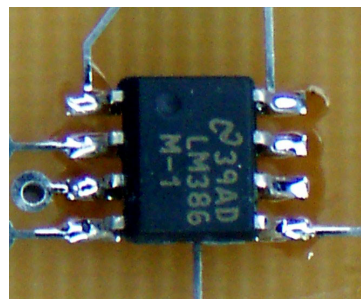

U5 LM386 Audio Amp

## Section 5: Installing Parts from the Controls and Connectors Bag

### 1) Install Pinheaders & Sockets

Using the Component Layout Diagram in Appendix A as a guide, install all pinheaders and strip sockets on the Component side of the board ...

#### QTY

[ ] 2            **P1, P2**            **Pinheader, 2x34 (HC908)**

It's really important to insert the **longer-side pins** of P1 & P2 into their respective holes **from the Bottom/Controls side of the pc board**. Then, since the black plastic part of the connector body is on the bottom, you'll need to carefully solder the pins on the Top/Component side. When you solder the pins, take care to not let the solder wick up the pins, as the HC908 Daughtercard sockets will need to fit down onto these pinheaders. (Just heat the pad and very lowest part of each pin, then quickly apply a \*small\* amount of solder.) When all the pins have been solders, snip off the pins on the Bottom/Controls side of the pc board. See photos below for reference.

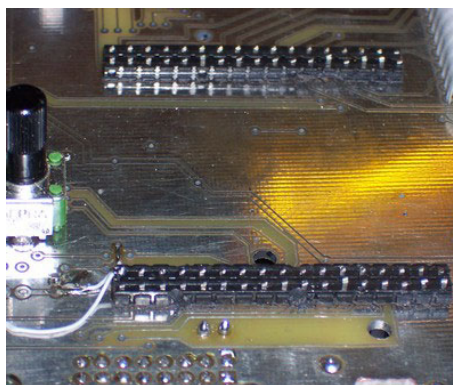
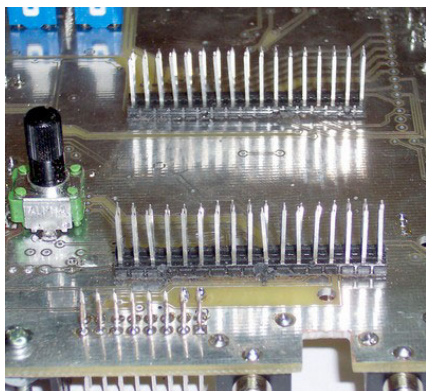

[ ] 2            **P3, P4**            **Pinheader, 1x2 pos'n (MON & NiMH)**

[ ] 1            **J8**                **Socket, 1x12 pos'n (DSP out)**

[ ] 1            **J9**                **Socket, 2x10 position, (DSP in)**

[ ] 1            **J10**              **Socket, 1x8 pos'n, right angle (for DDS Daughtercard)**

This is the right-angle connector for the DDS Daughtercard and it will be important to get it soldered in at the correct height above the pc board. First install one nylon spacer to the Top/Component side of the pc board located at the top right corner of the silkscreen indication for the DDS card. (This hole is located near components R15.) Use nylon screw to hold it in place. This single standoff will be the resting point for the DDS card once it is installed. Next, stick J10 on the end connector of your DDS Daughtercard with the pins of J10 extending down toward the bottom/ground side of the DDS card. Insert the pins of J10 into the pc board from the Top/Component side such that the attached DDS card is resting on the just-installed nylon spacers. Solder the J10 pins from the bottom side while holding the DDS card steady and parallel to the pc board, and snip off the pins. Proper orientation will be as shown below

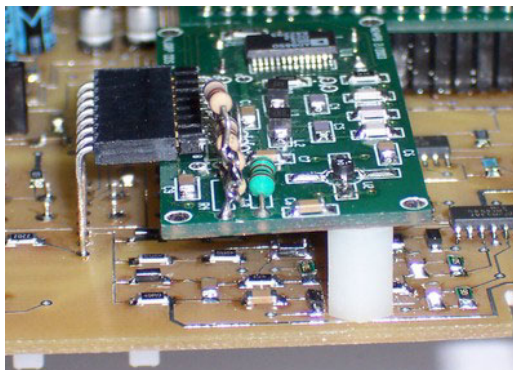

## 2) Install Thru-hole Components

Using the Component Layout Diagram in Appendix A as a guide, install all thru-hole components on the Component side of the board ...

### QTY

[ ] 3            **C&, C33, C34    Capacitor, 1 uF, Electrolytic**

Note that an engineering mod has already been done to the board in the positions for C33 and C34 to correct for a pad layout error. In each case, the longer/positive lead of the capacitor goes in the '+' pad, and the negative lead goes in the small 'via' hole associated with the test point for that signal line (neg lead of C34 goes to the 'Aud-L' hole, and the neg lead for C33 goes to the 'Aud-R' hole.) You will need to scrape the green soldermask off these small holes using a sharp razor blade, thus exposing the copper for soldering.

[ ] 2            **C5, C26            Capacitor, 10 uF, Electrolytic**

When installing these radial-lead, thru-hole electrolytics, **be sure to properly identify the component polarity.** As shown in the photo below, the longer lead is the positive and the shorter is the negative (which is also identified with the black stripe on the side of the component.) Be sure to insert the positive/longer lead in the pc board hole closest to the silkscreened '+' sign.

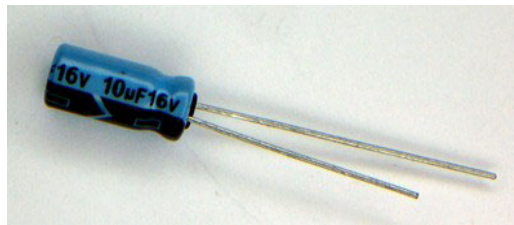

[ ] 1            **C27                Capacitor, 47 uF, Electrolytic**

[ ] 1            **C24                Capacitor, 100 uF, Electrolytic**

[ ] 1            **R43                Resistor, 10, 1/2W**

[ ] 1            **R47                Resistor, 47, 1/2W**

## 3) Install Connectors

Using the Component Layout Diagram in Appendix A as a guide, install most connectors on the Component side of the board. **It is very important to mount these components on the Top/Component side of the pc board.** Most of these connectors and their pads are symmetrical, so you could mistakenly mount them on the wrong side. Double-check the Completed PC Board Assembly photos in Appendix E to ensure that you are inserting these connectors to the proper side of the pc board.

### QTY

[ ] 1            **J1                 BNC, pcb mount**

[ ] 1            **J2                 Serial port connector, DB9F**

[ ] 1            **J4                 Coaxial power connector, 2.1mm**

[ ] 1            **J11                Mini-DIN, 6 pos'n (KBD)**

[ ] 3            **J6, J7, J12        Audio jack, 1/8", pcb mount (remove mounting nut)**

[ ] 1            **J14                Mini-Din, 8 pos'n (AUX)**

[ ] 1            **S2                 Slide switch, pcb mount, SPST**

#### 4) Install Controls

Using the Component Layout Diagram in Appendix A as a guide, install all controls on the Bottom/Controls/Ground side of the pc board. It is really important to install these components on the Bottom/Controls side of the pc board. Double-check the Completed PC Board Assembly photos in Appendix E to ensure that you are inserting these connectors to the proper side of the pc board.

##### QTY

[ ] 1

ENC

**Rotary Encoder**

The encoder needs a little preparation before you assemble it to the pc board. Using some side cutters/diagonals (and preferably heavy-duty ones), you must first snip off the zinc cast alignment nub that sticks up in the same direction as the shaft. Taking off this small piece will allow the encoder to sit flush up underneath the front panel of the enclosure. Also, the encoder shaft is too long for our purposes here, so you'll need to use a hack saw (or equiv) to saw off about one half the length of the flat-sided end of the shaft. This will leave about 1/4" of the flat shaft, which will be fine for attaching the knob later on.

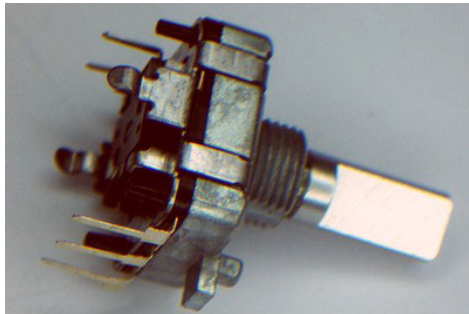

[ ] 1

R45

**Potentiometer, 10K, miniature, pcb mount**

[ ] 5

PB1, PB2, PB3, PB4, PB5

**Pushbuttons, SPST, momentary contact**

When installing these pushbuttons, it's very important to orient them as shown in the photo below. Each pushbutton must have the white tabs on the side of its body oriented to the right/left of the board (i.e., toward the speaker and J9). Otherwise the switch input lines to the MPU will always be shorted.



[ ] 5

**Pushbutton caps**

[ ] 1 **SPKR Speaker, miniature, 32-ohm**

When soldering this component in place, be careful to orient the leads so the pin marked with a '+' is placed in the hole closest to the silkscreened '+'. Be sure not to apply too much heat while soldering, as the plastic of the speaker body can easily melt and deform. Lastly, leave the speaker a little elevated (about .04") from the pc board, as this will allow it to better reach up to the front panel hole. See photo below for reference.

[ ] 1 **LED1 LED, T1-3/4 (BUSY) (From Semiconductor Bag)**

The cathode of the LED is indicated by the shorter lead and a slight notch in the side of the red plastic body. The anode must be mounted toward the upper end of the board, toward the straight line indication on the silkscreen. In order for the LED to reach up through the front panel, it should be mounted about 0.3" up off the pc board. See the photo below for reference.

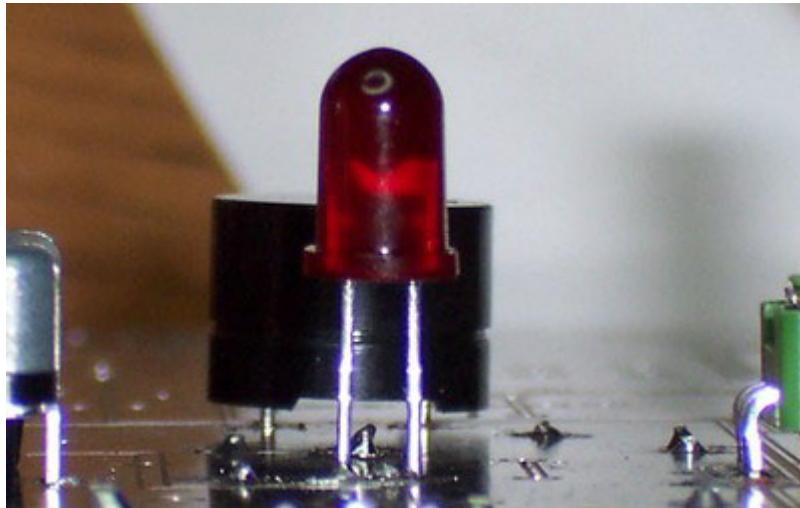

#### 4) Install Test Points

We provided for some important signals to be readily accessible to your DVM or oscilloscope probes during the instruction checkout. These "Test Points" are merely small "loops" of wire made from of scrap component leads that are soldered onto adjacent pads on a trace of a specific signal.

(Note: installation of the wires in this small test point holes is optional. If you do install them, you will need to gently scrape away the green soldermask from the holes to expose the copper pads, thus enabling the test point wires to be soldered.)

- [ ] **Install Test point 'GND' located in lower left corner of the board.**
- [ ] **Install test point '+V' located in lower-middle area of the board.**
- [ ] **Install test point 'RF' located in the top-right corner of the board.**
- [ ] **Install test point '+5' located to the right of regulator U1.**
- [ ] **Install test point 'Aud-R' located in the middle of the board near C33.**
- [ ] **Install test point 'Aud-L' located in the middle of the board near C34.**

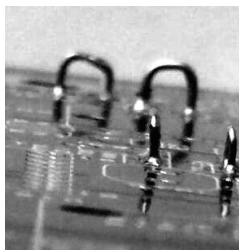

Another project board is shown here to illustrate installation of a test point.

## 5) Install LCD

Using the Component Layout Diagram in Appendix A as a guide, install the LCD on the Bottom/Controls/Ground side of the pc board ...

<b>QTY</b>		
[ ] 1	<b>LCD</b>	<b>Display, LCD, Hantronix, 16x2 STN, GRAY</b>
[ ] 1	<b>W1</b>	<b>Jumper, Flexstrip, (LCD)</b>

You'll use the 16-wire flexible jumper W1 to connect the LCD to the pcb, as shown in the photos below. Bend the wire jumper at the midpoint and fold it out (away) from the LCD as shown below in preparation for attaching the LCD to the nylon standoffs on the pc board. (Folding outward keeps the pins from the LCD pcb from rubbing/penetrating the insulation and shorting to the signals.)

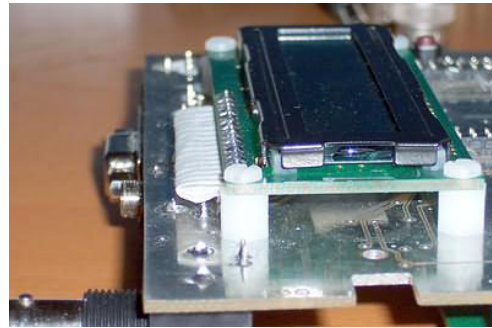
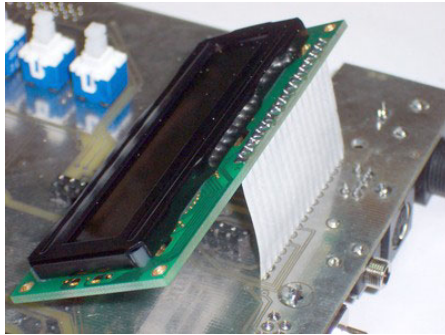

Locate eight nylon screws and using your wire cutters/diagonals, nip 1/16" off the end of each. This amounts to about 1.5-2 "threads" as you position the cutters on the shaft of the screw, as shown below. We have to do this because the spacers we'll use in the next step are short and the screws will not insert far enough to seat the LCD on one side and the pc board on the other.

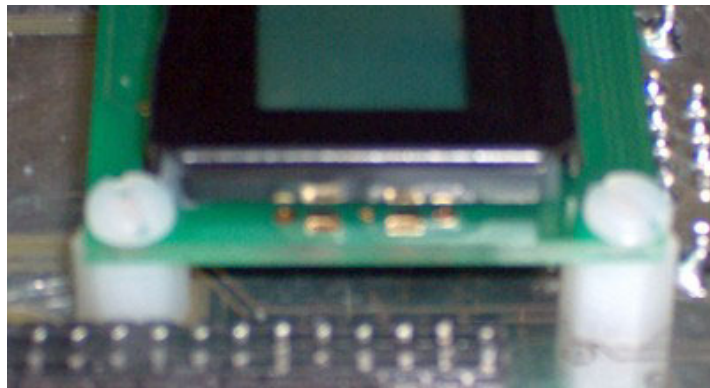
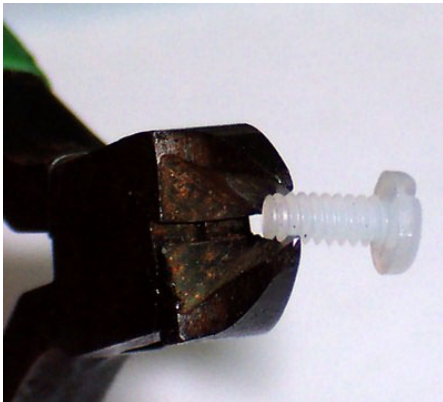

Locate the four shorter, 0.25" nylon spacers. Be sure these are the shorter ones supplied in the kit. Attach all four spacers on the Bottom/Controls side of the pc board using four of the shortened nylon screws, as shown in the upper-right photos. Be careful not to over-tighten the nylon hardware, as you'll strip out the threads.

Next, you will screw the four remaining shortened nylon screws through the corner holes of the LCD and into the threaded spacers mounted on the board. NOTE: The four holes in the corners of the LCD are smaller than the screws, but by applying a little pressure while turning them into the holes, you will "thread" them into the holes and subsequently into the spacer below. (If you have trouble with this, you can use an appropriately-sized drill bit to carefully enlarge the LCD mounting holes.) Again, be careful not to over-tighten the nylon hardware. When complete, the LCD should look as shown in the upper-right photo.

---

## **Section 6: Power-up and Test**

### **[ ] Prepare for the Tests**

When first ready to apply power to the newly-assembled Micro908, position the pc board on the bench (without the enclosure) and with the LCD and controls side facing up. This will enable you to more easily get to the components and you can spot gross problems (like exploding capacitors, smoking regulators, etc.) should they occur.

Make sure the shunt (small, black 1x2 position jumper socket) is removed from P3.

Install the HC908 Daughtercard. Make certain the Heartbeat LED is oriented toward the bottom of the Micro908 pc board, as shown in Appendix D: Fully-Assembled PC Board

Do not install the DDS Daughtercard yet.

Do not install the DSP Daughtercard yet.

It's a good practice to use a current-limited external power supply when first testing out projects like the Micro908. You can set the maximum current to be about 500ma and be assured that a short circuit will not blast away circuit traces in the process of first applying power. A good alternative is to power the project from a battery on the bench. The similar effect can be gained by the natural limits of a battery to supply lots of current.

### **[ ] Apply power and see display on LCD**

After plugging in the power supply and moving the Power slide switch to the ON position (up), you will see the approximate power supply voltage displayed in the LCD for about ½ second, then the LCD will display the “main menu” message of “AA908 v2.0” on the first line, and “Select Command” on the second line.. If you don't see this indication on the LCD, proceed to the Troubleshooting section.

### **[ ] Press MODE Pushbutton and see Frequency, SWR, R and X display on LCD**

Pressing MODE pushbutton (also called the Manual Mode) will the displayed values for frequency, SWR, R and X displayed on the LCD. (You might need to turn the Dial a bit to see the full display appear.) The readings for SWR, R and X will be meaningless at this point since you do not yet have the DDS Daughtercard (i.e., the RF signal source) installed.

### **[ ] Turn Dial to Change Frequency**

Turning the Dial will result in changing the displayed frequency, starting at the digit that has the underline cursor beneath it. This digit will be the 10 kHz digit.

### **[ ] Press and Turn Dial to Change Cursor Position**

When you press-and-turn the Dial, the underscore cursor will move to the next-higher (or next-lower) digit in the frequency display, thus allowing you to change frequency at a more (or less) rapid rate. The cursor will stop at the rightmost digit despite further clockwise rotation of the Dial, thereby providing 10 Hz increments as the smallest allowable. Similarly, the cursor will stop at the leftmost position despite further counterclockwise rotation of the Dial, thereby providing 10 MHz as the greatest incrementing value of frequency.

### **[ ] Press the BAND Pushbutton to Select Band**

You can press the BAND pushbutton at any time to select one of four bands segments to automatically scan when you later press the SCAN pushbutton. The band segments are 1-10 MHz, 10-20 MHz, 20-30 MHz and “Custom Band”. (The Custom Band uses start/end limits that were previously set in the Configuration menus, discussed later.) The different Band segments are sequentially displayed while turning the Dial. A band is selected by pressing the Dial when the desired band is displayed. Once a band is selected, the display will show the Main display (“AA908 v2.0” / “Select Function”).

### **[ ] Press the SCAN Pushbutton to Scan the Band**

When you press the SCAN pushbutton, you initiate an automatic scan of the selected band. The LED is illuminated and the internal DDS signal generator is automatically set to the Start frequency for that band and the SWR is determined. The frequency is incremented by the Step value (default of 10 kHz and user-settable in Config) and the SWR is determined at this point. This sequence continues throughout the entire band until the End frequency is reached. Throughout the scanning, the software saves the frequency that yielded the lowest SWR and when the scan is complete, control is given to the Mode function that displays that point of lowest SWR. The display will show the frequency, SWR, R and X values for that point and the user is able to manually control the instrument as described in the Mode section above. Since the DDS signal generator is not yet installed, the Scan will likely exit showing a frequency of 1,000.00 MHz and an SWR of '>10'.

This is okay for now. If the LED did not illuminate at the start of the Scan, and turn off at the end of the Scan, make a note to visit the Troubleshooting section later on.

### [ ] **Press the CONFIG Pushbutton to get into the Configuration Menus**

The CONFIG pushbutton may be pressed at any time to access the Configuration menus. Please refer to the Micro908 Technical Reference and Operation Guide for a complete description of the available functions in this mode. But in summary, the user is allowed to specify Start/End frequencies and Step size for a Custom Band, turn the Tones On/Off, Update the Software, turn on DEBUG Mode, access the low-level Debug Monitor (HCmon), Display the battery voltage, Calibrate the instrument, and Exit back to the Main display.

### [ ] **Select TONE ON to hear Audio Indication of SWR**

While in the Configuration menus, turn the Dial until 'Tone ON' is displayed and then press the Dial to select it. Rotate the Dial until 'Exit' is displayed and press the Dial to exit. A message on the second line of the LCD will indicate that the changed settings are being saved (to nonvolatile EEPROM memory) and then the Main display will show once again. Press the MODE pushbutton to see the frequency display in Manual Mode and immediately hear a high-pitched tone coming from the speaker, indicating that a high SWR reading is currently being displayed. If you do not hear a tone, make a note of later checking it out in the Troubleshooting section. When we later install the DDS Daughtercard and an antenna (or dummy antenna), you will note a variable pitch being generated when the Dial is tuned through a resonance. A lower tone indicates a lower SWR being measured. In order to preserve your sanity (and hearing) during the remainder of the tests, go back into Configuration menu to turn the Tone OFF.

### [ ] **Select 'Software Load from CONFIG Menu**

You will test the RS232 serial port on the Micro908 now, so connect a 9-pin, "straight-through" serial cable (not a "null modem cable") between your Micro908 pc board (connector J2) and a PC running a dumb terminal program such as HyperTerm. Configure the terminal program to run with settings of "9600 N81" (9600 baud, No parity, 8 bits, 1 stop bit). In the Micro908 Configuration menu, select 'Software Load' and see a line of data displayed on the PC screen that shows "HCmon>" and intelligible letters and numbers following it. If you do not see this indication on the PC screen, make a note to check it out in the Troubleshooting section.

### [ ] **Turn the Micro908 power switch S1 to OFF**

### [ ] **Install the upgraded DDS Daughtercard**

After making the improvements to the DDS Daughtercard (per the simple instructions provided in that kit bag), install the DDS card into its connector J10. There will be no need to attempt to screw the DDS card onto the nylon standoff, as the holes do not line up. The DDS card should just sit atop the standoff with a little pressure.

### [ ] **Turn on the power to the Micro908**

After siding S1 back to ON, check that there is no smoke, sizzle or unexplained flashes of light coming from your DDS Daughtercard. The DDS chip, the MAV amplifier and the R4 bias resistor will indeed get warm to the touch, but not excessively so. If they do, power down immediately and go to the Troubleshooting section.

### [ ] **Attach Dummy Antenna to BNC connector J1**

We're going to measure some antenna characteristics here so you'll need a load. Ideally at this point, you should connect a "dummy antenna" that you might have previously prepared, per Appendix F. Alternatively, you can connect an antenna that is known-resonant at some frequency within the HF bands.

### [ ] **Get into Manual Mode (MODE Pushbutton) and See Measurements Change**

When you get into the Manual mode (by pressing MODE pushbutton), move the frequency up/down until you see a dip occur in the SWR display, indicating that you are approaching the resonant point of the dummy antenna. When you have found the minimum SWR "dip", move the cursor to the next lower position (by press-and-turning the Dial to move the underscore cursor) and continue turning the Dial to get finer resolution of the minimum SWR point. If you do not see this SWR dip condition happening, go to the Troubleshooting section to dig into the problem.

### [ ] **Select the Band that has the Resonance and SCAN**

Make sure you have selected the Band that contains the known-resonant frequency (1-10, 10-20 or 20-30 MHz) and press SCAN. The instrument will scan the band, and at the end it will display the antenna characteristics (SWR, R and X) found at the point of minimum detected SWR.

## [ ] Calibrate the Micro908 reflectometer channels for gain

You will need to calibrate the Micro908 Antenna Analyst when first constructed. The instrument may also need to be recalibrated later, such as when a new software update is available that changes the way in which calibration data are used, or when the level of the DDS signal source changes in any regard. In these cases, the instrument may be quickly and easily calibrated by following a short sequence of operations located in the “Calibrate” function, located beneath the CONFIG pushbutton.

1. Select the Calibrate function, located within CONFIG.
2. See “Calibrate now?” displayed in the LCD. Confirm by selecting “yes” with the dial. (Press the dial when “yes” is displayed.)
3. See “Open load?” displayed on the LCD. Ensure that nothing is connected to the RF output jack, then confirm by selecting “yes” with the dial.
4. See a display of four 2-digit hexadecimal numbers representing the reflectometer channel voltages for  $V_f$ ,  $V_r$ ,  $V_z$  and  $V_a$ . If a trimpot is provided on your DDS Daughtercard, adjust it such that none of the readings exceeds about C2. This will correspond to a voltage on the open circuit BNC output connector approximately equal to 2 volts peak-to-peak (as seen with an oscilloscope) or about 700 mVrms (as seen with an RF probe on a DMM). Ensure that the first three hex numbers are these “high” values and that the last number ( $V_a$ ) is very close to zero (e.g., 04). *[NOTE: See the “Hexidecimal numbers” explanation at the bottom of the page.]*
5. If the displayed numbers are in the acceptable range, as explained above, press the Dial with “yes” selected in order to continue. However, if the “3 high and one low” condition of numbers is not present, or if any channel is very high in the hex number range of F0 to FF, then a successful calibration is not possible and you should contact Support.
6. See “Shorted load?” displayed on the LCD. Place a short circuit on the RF output jack and select “yes” with the dial. *[NOTE: You might consider constructing a shorted BNC plug to conveniently serve as this shorted load.]*
7. See “270-ohm load on?” displayed on the LCD. Place the supplied 274-ohm resistor on the RF output connector and confirm by selecting “yes”. *[NOTE: You might consider constructing a BNC plug containing this 274-ohm resistor to conveniently serve as this load.]*
8. See “Make SWR=5.4” displayed on the first line of the LCD, and a number on the second line. Adjust the dial to make the number on the second line be as close as possible to 5.4. Press the dial when this number is 5.4.
9. See “50-ohm load on?” displayed on the LCD. Place a the supplied 49.9-ohm resistor on the RF output connector and confirm by selecting “yes” with the dial. *[NOTE: You might consider constructing a BNC plug containing this 49.9-ohm resistor to conveniently serve as this load.]*
10. See “Saving data” displayed on the LCD and the red BUSY LED will turn on for several seconds.
11. When the BUSY LED turns off, “Exit” will be displayed on the LCD. Confirm by pressing the dial and control will again be placed in the Impedance mode, with measurements being made using the newly-created calibration data.

### Aside 1: “What is being calibrated?”

In order to normalize the gains of the four reflectometer channels with respect to each other, the software creates “gain correction factors” for the  $V_r$ ,  $V_z$  and  $V_a$  channels. When each channel is multiplied by its respective correction factor, it will equal the value of the  $V_f$  channel, as determined under the specific conditions of open/short/50-ohm loads presented during the calibration sequence. These correction factors are then used during the normal operation of reading raw  $V_r$ ,  $V_z$  and  $V_a$  signals to compute the SWR, R and X values displayed on the LCD in Impedance mode. The correction factors are saved away to nonvolatile memory such that they can be used each time the instrument is turned on.

## Aside 2: The Importance of a Good DDS Signal

We have a spectrum analysis screen shot representative of a well-calibrated Antenna Analyst on the Micro908 project page at <http://www.amqrp.org/kits/micro908>. It shows the second harmonic >30 dB down from the fundamental, which is a very good and important characteristic of the DDS signal generated in the instrument.

Signal quality such as this is important for use with the Antenna Analyst where an RF signal is being used as a test stimulus, and is correspondingly being measured with an antenna network attached. The signal should be as purely sinusoidal as possible such that the signal integrations being made in the reflectometer, and being amplified by U3 and U4, and being measured by the microcontroller, are accurate representations of the characteristics of the antenna system at the frequency of interest.

In contrast, if the harmonics of the DDS signal (i.e., frequency components other than just the fundamental frequency displayed on the LCD) are too high in level compared to the fundamental, the accuracy of the Antenna Analyst suffers. The harmonics are also being integrated by the reflectometer, right along with the “good” fundamental frequency, and they start affecting the measured results. We don't want frequencies other than the fundamental to be used - otherwise, the computed/displayed results will be inaccurate for the frequency we desire.

So, the moral of the story is to adjust the DDS card to generate the best-looking signal possible! If you have an oscilloscope, check the open circuit voltage at the output BNC connector to ensure that its sinusoidal symmetry is good and that its level is approximately 2V p-p. If you also have a spectrum analyzer, you should ensure that the signals harmonics are all more than 30 dB below the level of the fundamental frequency.

## Aside 3: “What is a hexadecimal number?”

You might not understand the meaning of a voltage of 'C2' as displayed on the Micro908 LCD during calibration, so here is a brief "hexadecimal numbering" primer that will explain how hexadecimal notation is used in the Micro908 and most other computers.

The range of the 8-bit hexadecimal numbers used in the Micro908 computer is ...

00, 01, 02, ... 09, 0A, 0B, 0C, 0D, 0E, 0F,  
10, 11, 12, ... 19, 1A, 1B, 1C, 1D, 1E, 1F,  
20, ...  
30, ...  
40, ...  
50, ...  
60, ...  
70, ...  
80, ...  
90, 10, 92, ... 99, 9A, 9B, 9C, 9D, 9E, 9F,  
A0, A1, A2, ... A9, AA, AB, AC, AD, AE, AF,  
B0, ...  
C0, ...  
D0, ...  
E0, ...  
F0, F1, F2, ... F9, FA, FB, FC, FD, FE, FF

Where 00 = 0 Volts, and FF = 5 Volts.

Hence a voltage of '80' hex (halfway between 00 and FF) represents 2.5V

Another way to look at it is we have a 0-5V A/D converter with 256 steps (00 to FF), or  $5/256 = 19.5$  mV per step.

You can see that a number of C2 (hex) = 194 (decimal) by using the hex calculator in your Windows Accessories folder. 'C2 steps' then corresponds to a reading of  $194 \times 19.5$  mV = 3.783 V

So when we say that "a reading of FF is too high and saturating the A/D channel", you'll know what we mean! ☺

## Section 7: Installing the PCB in the Enclosure

Now that the functional tests are complete, you can finish the final assembly of the Micro908 by installing it into the enclosure. (NOTE: The enclosure is an optional item and may not have been purchased. If this is the case, you are done!) Refer to the Mechanical Assembly diagram in Appendix E for a detailed “exploded view” described in this section.

When this section is complete, your Micro908 will look something like the photo below.

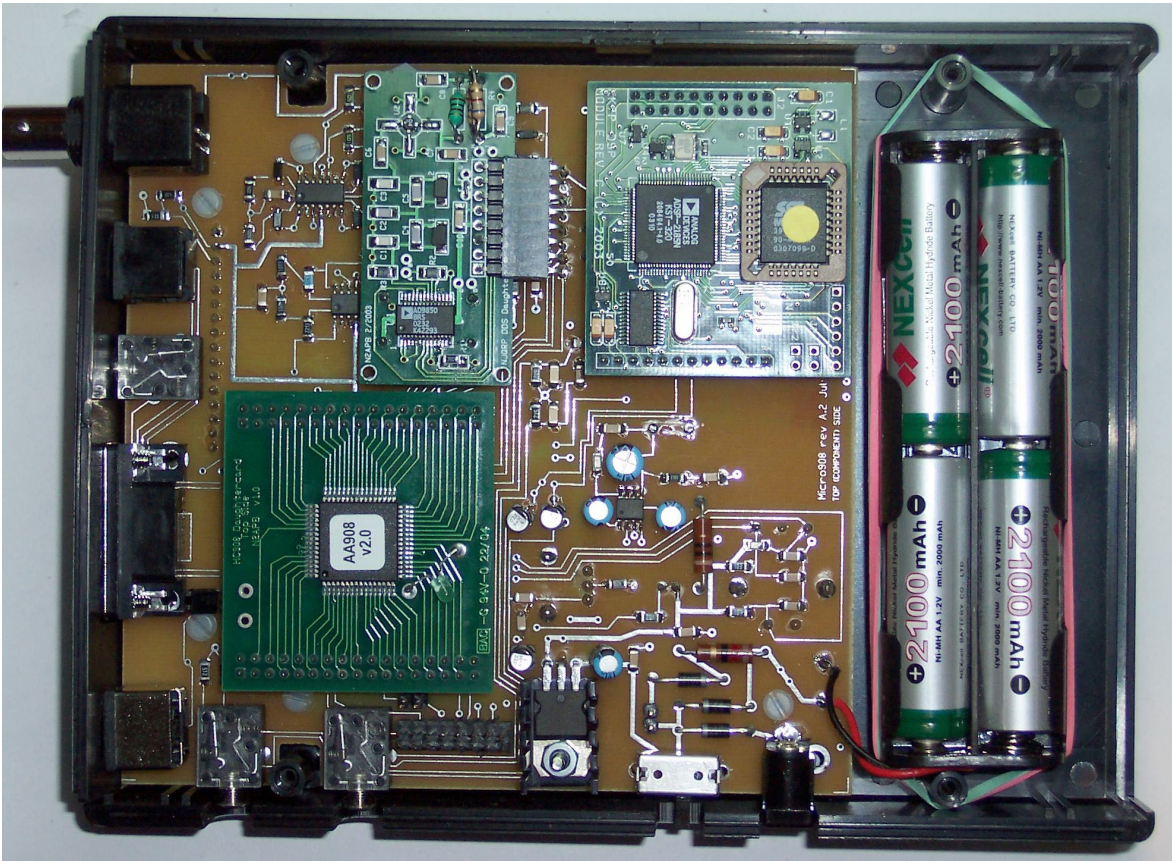

Fully-Assembled Micro908 PCB mounted in the Top Shell of the Enclosure

### [ ] **Apply Overlay Label to Drilled End Panel**

Locate the black overlay with white labels and carefully apply it to the drilled end panel. Carefully peel back the protective paper from the sticky side off the overlay and lay it down on the side of the end panel that is “raised” around the edges – that is, the fully-flat side of the end panel will end up being on the inside of the Micro908, so you want to apply the overlay label to the outside surface. Be careful not to misalign the label, as it is very difficult to remove.



**Pre-Drilled End Panel with Overlay Label attached**

### [ ] **Install spacers on inside of top shell**

Locate four of the longer nylon spacers and the four flathead nylon screws. (Flathead screws have an angled head that allows them to be countersunk in the plastic to lie flat with the surface of the enclosure and thus provide a smooth overall finish.) Connect the four nylon spacers to the inside of the top shell using the flathead nylon screws at the countersunk positions in the enclosure shell.

### [ ] **Apply front Panel Overlay Label to the Top Shell**

Once again, peel back the protective paper from the large yellow front panel overlay label and carefully align it over the holes and to the edges of the enclosure shell. Once in place, the overlay label will cover the nylon spacers just installed, so ensure they are snug before covering over the flathead screws.

### [ ] **Apply Side Panel Overlay Label to the Side of the Top Shell**

Locate and peel back the protective paper from the long, black (with white letters ‘ON’, ‘OFF’, etc.) side panel overlay label and carefully align it over the holes and to the edge of the side of the enclosure shell.

### [ ] **Place Drilled End Panel on Connector End of the PC Board**

Place the end panel on the connectors at the edge of the Micro908 pc board, with the label side facing out/away from the board. The end panel will only go on one way and it can remain loosely in place.

### [ ] **Install the PCB Assembly into the Top Shell**

Carefully slide the pc board into the top shell, making sure to guide the loose end panel into the slots at the top end of the enclosure shell while also guiding the edge connectors and front panel controls through the appropriate holes. Although it may seem like a tight fit, it should drop into position real nice once everything is aligned. If you have problems with a fit being too tight, you might not have filed the side post holes in the pc board large enough, or you might not have filed the top and side edges of the pc board enough to allow the fit. Once the PCB assembly is in place, use the four remaining nylon screws to connect the pc board to the nylon spacers previously installed on the inside of the enclosure top shell. The holes for these screws are located near J6, J4, U3 and D11. *(NOTE: You may need to deepen and widen the slots on the case for the Audio In/Out jacks to allow cables plugging into the jack to seat properly. This can easily be done, as necessary, with a round/rattail file.)*

### [ ] **Install the Battery Holder**

If not already done, solder the wires from the battery holder to the pc board at the points marked ‘BATT’. The red wire goes to the ‘+’ pad and the black wire goes to the ‘-’ pad. The battery holder (and heavy batteries) can effectively be held in place with some rubber bands holding the assembly to the two molded enclosure posts, as shown in the photo at the top of this section. Additionally, a strip of the small bubble wrap supplied in the Kit may be cut off and affixed to the inside of the enclosure above/below the battery holder to further act as a cushion for the battery assembly.

### [ ] **Install the other End Panel**

Slide the uncut plastic end panel into position at the bottom end of the enclosure shell. Be sure that it is contained in the small slot at the end of the shell.

## [ ] Install the Bottom Shell of the Enclosure

Place the bottom black plastic shell of the enclosure in place and use the four 3/4" self-tapping screws to secure it to the top shell.

## [ ] Install Rubber Feet

Peel off the four rubber feet and apply them to the corners of the enclosure's bottom shell.

## [ ] It's "Miller Time"!

Assembly of the Micro908 is complete.

---

## Section 8: Troubleshooting

In this section we'll help you get your Micro908 instrument working if it doesn't behave as described when power is first applied. You'll need some basic equipment, the schematic from Section B and the pc board layouts from Section C.

### Equipment Needed

If you have an oscilloscope that's good to 100 MHz, you'll be all set to probe at all the signals inside the Micro908. But at a minimum, you'll need a volt-ohmmeter (DVM) for DC voltage and resistance measurements. You'll also need an RF probe in order to see the RF voltages that we're dealing with in this instrument. If you don't have an RF probe, like the AccuProbe from the NorTex QRP Club, it's pretty easy to make a simple one. The one shown below can be made up in less than an hour from common junk box parts. If you want to get fancy you could install the components on a narrow piece of perf board and slide it into an old metal cigar tube for shielding. Otherwise just have the probe made from stiff wire affixed to the end of that narrow perf board and an alligator clip for ground. Then with your DVM probe connected to the back end, you can hold the perf board with the "probe tip" at the front end and use it to probe around the circuit.

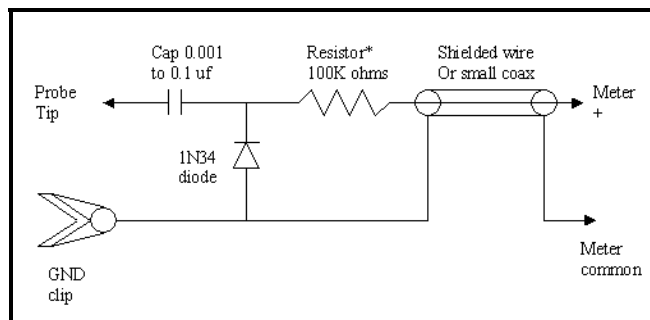

Simple RF Probe (by Phil DeCaire, WB7AEI, described in QRP Homebrewer #9)

### Basic Tests

We'll assume you haven't seen any smoke coming from the circuit board or components. That's always a good starting point for a successful repair of a unit. Otherwise, you'll obviously need to look in the area when the smoke came from, or where the board and components look charred – for that is the place where a component was mis-installed or the place where the problem surfaced from something else (e.g., reversed power supply, etc.)

### Power Supply

If you are operating from batteries, be sure the terminal voltage on the battery holder is at least 8.5V. If the level is below that, the RF signal will not be generated properly, or at all, and you will not get expected readings displayed on the LCD.

If operating from an external source, make sure the voltage level does not exceed 16V DC. Beyond this maximum specification, the regulators will be required to dissipate too much power and they'll get too hot for normal operation. Further, the "battery monitor" voltage divider R28 and R41 will present more than 5V to the A/D on the MPU, which would not be too nice.

Make sure you have your battery polarity proper with the wires going to the circuit board, and be sure the connector supplying external power is wired with positive-to-center on the mating plug to J4. If either connection is reversed, your board will not be damaged, but it won't receive the necessary voltage to make it work. In that case ... fix it!

With the power switch ON, and the ground probe of your DVM attached to the board ground at the GND test point (located at the bottom-left of the pc board), measure your supply voltage at the +V test point at the +V test point (located at the bottom-center of the pc board). If you don't see the proper voltage, your problem is in the diode arrangement around the battery or power connector and power switch S2.

Measure +5V at the test point located just to the right of regulator U1. If you don't see +5V here, there is likely something pulling down the 5V bus on the board. In this case, U1 is likely getting pretty hot. Power down the unit and find the cause of the problem, which is likely a solder short on any of the closely-spaced terminals of the components or connectors. Also, make sure that the HC908, DDS and DSP daughtercards are oriented properly within their sockets. If they are plugged in backwards (180-degrees out), or shifted up/down one position, chances are this is causing the power supply problems. It's also likely that the daughtercard is damaged (or at least suspect), unfortunately.

## **Specific Problems**

### **Problem: "The frequency doesn't increment or decrement properly when I turn the Dial"**

The fact that the Dial has some effect at all is a good thing and indicates that your board is very likely working. We needed to change the pc board artwork after the HC908 Daughtercards were programmed with "version 2" and you will need to download the latest software (version 3.0) from the project website and load it into your Micro908 using either of the techniques described in Appendix G: "Loading New Software into the Micro908." There will be many occasions of loading new software in the future, so might as well get into it right now! We're sorry that were not able to

### **Problem: The Serial port isn't sending data to my PC during the 'Debug Monitor' tests.**

The RS232 serial port signals of the HC908 Daughtercard were tested at assembly time, so the only possible causes of this condition are the serial cable (needs to be a "straight-thru" cable, not a null modem), or the setup of your terminal program (HyperTerm or whatever). Please check the appropriate section describing these settings to ensure that you have configured the program properly on your PC and that you have the serial port free of any other program trying to control it.

### **Problem: The LED is not illuminated during a Scan.**

You should see a low voltage level at the top of R8 during a Scan and a high one (~5V) when the Scan is complete, corresponding to the LED turning on and off, respectively. If the signal levels are okay, but still no LED illumination, you may have the LED oriented backwards. See the appropriate assembly section to review details for proper orientation.

### **Problem: No tone is heard when reading SWR with the Tone enabled from the Config menu.**

You should see an approximate 3V audio frequency signal on the left side of C40, and be able to trace that through R45, U5, C24 and then on to the speaker itself. If the signal is there, but still there is no sound, you might have damaged the speaker during installation. *[NOTE: The tone will 'beep' at approximate 1-second intervals ... this is normal.]*

### **Problem: The readings for SWR, R and X are not changing, or are way off, when I move the Dial or do a Scan.**

There may be several causes for this condition.

- 1) Ensure that you have downloaded the latest version of software from the Micro908 web pages and have performed gone through the calibration steps (located under the CONFIG pushbutton).
- 2) You may not have proper signal levels coming from the DDS Daughtercard. With no load connected to the RF Out jack (J1), dial up a frequency of 1,000.00 and probe the output of the DDS card (J10 pin 6). You should see about 4 Vp-p, or about 1.4 Vrms using an RF Probe. If you do not see these approximate signals, nothing "downstream" will work right and you will need to find the cause of the problem before proceeding.
- 3) You may have a component problem (wrong part, solder short, etc.) in the reflectometer or buffer amplifiers. Use the following charts to determine if you have the proper levels at the specified points in the circuitry under conditions on J1 of: open circuit, short circuit, and 50-ohm loads. Try to narrow the problem down to a specific channel (Vf, Vr, Vz and Va), and then to a specific point in that signal chain.

## Voltage Charts

Typical LCD display of Reflectometer readings in Calibration for the three calibration conditions of **Open** circuit load, **Short** circuit load, and **50-Ohm** circuit:

	Vf	Vr	Vz	Va
<b>Open</b>	FB	FB	FB	01
<b>Short</b>	8C	8F	02	8D
<b>50-ohm</b>	C5	04	67	60

Typical voltages for the four Reflectometer op amp channels in the three calibration conditions of **Open** circuit load, **Short** circuit load, and **50-Ohm** circuit:

	VA	VZ	VR	VF
<b>OPEN CIRCUIT</b>				
Reflectometer output	U3 pin 3 = 0	U3 pin 10 = 1.9	U3 pin 12 = 0.8	U3 pin 5 = 1.8
First op amp output	U3 pin 1 = 0	U3 pin 8 = 2.1	U3 pin 14 = 0.9	U3 pin 7 = 1.9
Second op amp output	U4 pin 1 = 0	U4 pin 8 = 4.8	U4 pin 14 = 4.8	U4 pin 7 = 4.8
<b>SHORT CIRCUIT</b>				
Reflectometer output	U3 pin 3 = 0.7	U3 pin 10 = 0	U3 pin 12 = 0.8	U3 pin 5 = 0.7
First op amp output	U3 pin 1 = 0.8	U3 pin 8 = 0	U3 pin 14 = 0.3	U3 pin 7 = 0.8
Second op amp output	U4 pin 1 = 2.7	U4 pin 8 = 0	U4 pin 14 = 2.7	U4 pin 7 = 2.7
<b>50-OHM CIRCUIT</b>				
Reflectometer output	U3 pin 3 = 0.5	U3 pin 10 = 0.5	U3 pin 12 = 0	U3 pin 5 = 1.0
First op amp output	U3 pin 1 = 0.6	U3 pin 8 = 0.6	U3 pin 14 = 0	U3 pin 7 = 1.2
Second op amp output	U4 pin 1 = 1.9	U4 pin 8 = 1.9	U4 pin 14 = 0	U4 pin 7 = 3.8

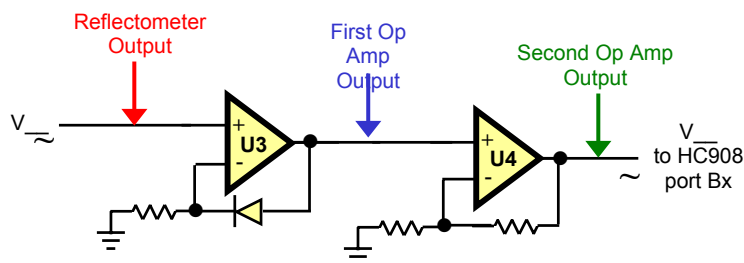

Diagnosing problems using the four hexadecimal voltages displayed on the LCD at the start of Calibration ...

### 1) Typical OPEN CIRCUIT Display: Vf = C0; Vr = B9; Vz = CA; Va = 04

An open circuit will show high voltages for Vf, Vr, and Vz. (High voltages can range from 90, 91, ... C9, CA, CB.) These high voltages are because the open circuit presents a very high reflected signal (Vr) and an infinite impedance (Vz). The Vf signal is always high, as it feeds the reflectometer. The Va is a low voltage because of the open circuit. (Va is the measure of voltage across R14, which is in the top right leg of the reflectometer. It has no current going through it when nothing is connected to the RF output jack, and thus the voltage is very close to zero. If Va is not close to zero then there is a problem in a component in the Va channel (from the reflectometer through the two op amp buffers), or a solder short along there.

### 2) Typical SHORT CIRCUIT Display: Vf = 8C; Vr = 8F; Vz = 02; Va = 8D

This short circuit condition brings the middle node of the right resistor leg in the reflectometer to ground. Thus the Vz voltage will read close to zero and the Va signal will read "high". If the Vz channel doesn't go very close to ground potential (00), then there is a problem in a component in the Vz channel (from the reflectometer through the two op amp buffers), or a solder short along there.

### 3) Typical 50-OHM Display: Vf = C5; Vr = 04; Vz = 67; Va = 60

When placing the 50-ohm load on the RF connector, you are presenting a "balanced Wheatstone bridge" condition to the reflectometer circuits, and the reflected signal (Vr) will be very close to zero. If the Vr channel doesn't go very close to ground potential (00), then there is a problem in a component in the Vr channel (from the reflectometer through the two op amp buffers), or a solder short along there.

## APPENDIX A: Micro908 Parts List

### SURFACE MOUNT COMPONENTS SHEET

Resistor Card 1		
1	R46	Resistor, 10, SMT, 1206
3	R11, R12, R14	Resistor, 49.9, SMT, 1206, 1%
1	R7	Resistor, 330, SMT, 1206
1	R8	Resistor, 1K, SMT, 1206
1	R6	Resistor, 4.3K, SMT, 1206
1	R44	Resistor, 4.7K, SMT, 1206
4	R37, R38, R39, R40	Resistor, 5.1K, SMT, 1206
12	R1, R2, R3, R4, R5, R17, R18, R22, R23, R27, R42, R48	Resistor, 10K, SMT, 1206
1	R41	Resistor, 10.0K, SMT, 1206, 1%
Resistor Card 2		
1	R1 (DDS card)	Resistor, 12.1K, SMT, 1206, 1%
1	R28	Resistor, 22K, SMT, 1206, 1%
4	R10, R13, R15, R49	Resistor, 47K, SMT, 1206
4	R19, R24, R29, R51	Resistor, 71.5K, SMT, 1206, 1%
4	R16, R21, R26, R50	Resistor, 220K, SMT, 1206
3	R20, R30, R52	Resistor, 221K, SMT, 1206, 1%
1	R25	Resistor, 549K, SMT, 1206, 1%
4	R32, R33, R34, R54	Resistor, 1M, SMT, 1206
Capacitors & Semiconductors		
4	C17, C19, C21, C41	Capacitor, 220 pF, SMT, 1206
2	C31, C32	Capacitor, 560 pF, SMT, 1206
7	C18, C20, C22, C23, C28, C40, C42	Capacitor, 0.01 uF, SMT, 1206
16	C1, C2, C3, C4, C6, C11, C12, C13, C14, C15, C25, C35, C36, C37, C38, C39	Capacitor, 0.1 uF, SMT, 1206
2	C29, C30	Capacitor, 0.33 uF, SMT, 1206
1	U6	IC, Level Translator, TC7SET08F, 5-lead SOIC
10	D1, D2, D3, D4, D5, D6, D10, D11, D12, D13	Diode, Schottky, 1N5711, SMT

### Controls & Connectors Bag

1	J1	BNC, pcb mount
1	J2	Serial port connector, DB9F
1	ENC	Rotary Encoder (ENC)
1	J4	Coaxial DC power connector, 2.1mm
1	J8	Socket, 1x12 pos'n (DSP out)
1	J9	Socket, 2x10 position, (DSP in)
1	J11	Mini-DIN, 6 pos'n (KBD)
3	J6, J7, J12	Audio jack, 1/8", pcb mount
1	J10	Socket, 1x8 pos'n, right angle (DDS card)
1	J13	Mini-Din, 8 pos'n (AUX)
1	W1	Jumper, Flexstrip, (LCD)
2	P1, P2	Pinheader, 2x34 (HC908)
2	P3, P4	Pinheader, 1x2 pos'n (MON, NiMH)
3	C7, C33, C34	Capacitor, 1 uF, Electrolytic, radial leads
2	C5, C26	Capacitor, 10 uF, Electrolytic
1	C27	Capacitor, 47 uF, Electrolytic
1	C24	Capacitor, 100 uF, Electrolytic
1	R43	Resistor, 10, 1/2W
1	R47	Resistor, 47, 1/2W
1	R-cal-50	Resistor, 49.9, 1%, 1/8W (for calibration)
1	R-cal-274	Resistor, 274, 1%, 1/8W (for calibration)
1	R45	Potentiometer, 10K, miniature, pcb mount
1	S2	Slide switch, pcb mount, SPST (POWER)
5	PB1, PB2, PB3, PB4, PB5	Pushbuttons, SPST, momentary contact
1	SPKR	Speaker, miniature, 32-ohm
5		Pushbutton caps (black)
1		Heatsink - TO220 (U1)
1		Knob, 1/4"-dia shaft, (ENC)
1		Nut, zinc plated, 4-40 (U1)
1		Machine screw, zinc plated, round head, 4-40 x 0.5" (U1)
4		Spacer, nylon, hex tapped, 4-40x0.25" (LCD)
6		Spacer, nylon, hex tapped, 4-40x0.375" (PCB+DDS)
16		Machine screw, pan slotted, #4-40x0.25" (PCB+DDS+LCD)
4		Machine screw, flat slotted, #4-40x0.25" (PCB-cover)
2		shunt, 0.1", 2 pos'n (MON, NiMH)
1		Desoldering Braid
1		Solder, 63/37 Eutectic, No-Clean Flux, @28 ga.

### Battery Holder Bag

1	LCD	Display, LCD, Hantronix, 16 char x 2 row
1	J3	Battery holder (for eight AA cells)
1		Flux Pen, No-Clean

### Semiconductor Bag

1	U1	Voltage regulator, 3-terminal, 7805, TO220
1	U2	Memory, SEEPROM, 512 Kbit (64 KB), 16-lead SOIC
2	U3, U4	IC, Op Amp, LMC6484, 14-lead SOIC
1	U5	IC, Audio Amp, LM386, 8-lead SOIC
1	LED1	LED, red, T1-3/4 (BUSY)
3	D7, D8, D9	Diode, Schottky, 1N5817, DO-41 (band indicates cathode)
1	Q1	Transistor, NPN, 2N3904, TO92

<b>PCB Bag</b>		
1	PCB	PC Board

<b>HC908 Daughtercard Bag (Optional)</b>		
1	HC908	HC908 Daughtercard assembly

<b>DSPx Daughtercard Bag (Optional)</b>		
1	DSPx	DSPx for Micro908 assembly

<b>DDS Daughtercard Kit Bag (Optional)</b>		
1	DDS Kit	DDS Daughtercard Kit

<b>DDS Chip Card (Optional)</b>		
1	AD9854BRS	DDS chip for DDS Daughtercard Kit

<b>Keyboard (Optional)</b>		
1	Keyboard	Dauphin Mini Keyboard

<b>Keyboard Cable Bag (Included with Keyboard Option)</b>		
1	Cable	Keyborad extension cable (6')

<b>Enclosure (Optional)</b>		
1	Enclosure	Pac-Tec LH-57 Enclosure (pre-drilled)

<b>Overlay Bag (Included with Enclosure Option)</b>		
1	Front panel overlay	Peel off back for self-stick, peel off clear front protection
1	Side panel overlay	Peel off back for self-stick, peel off clear front protection
1	End panel overlay	Peel off back for self-stick, peel off clear front protection
1	End panel (drilled)	
1	End panel (undrilled)	
4	Enclosure screws	
4	Enclosure rubber feet	

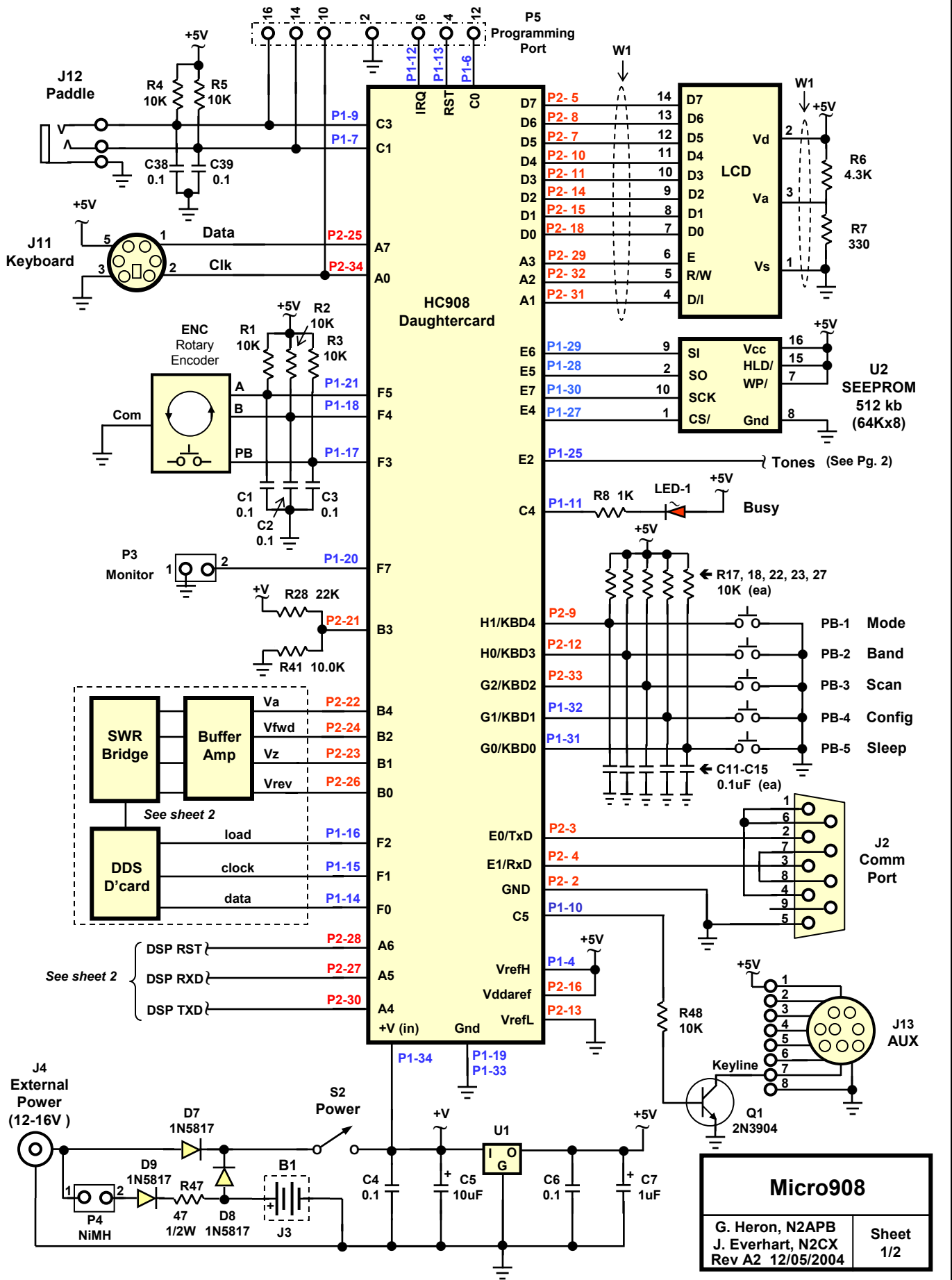

from HC908:

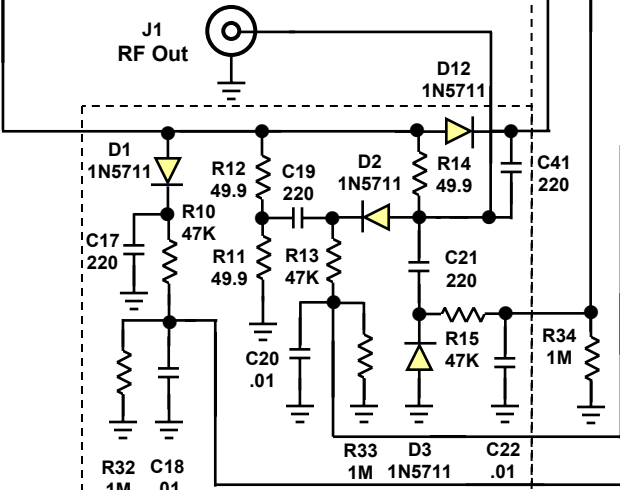
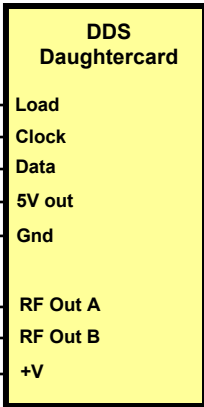
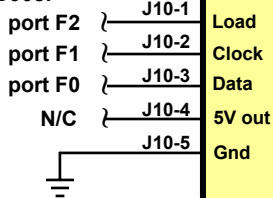

**Compensation & Buffer Amplifiers**

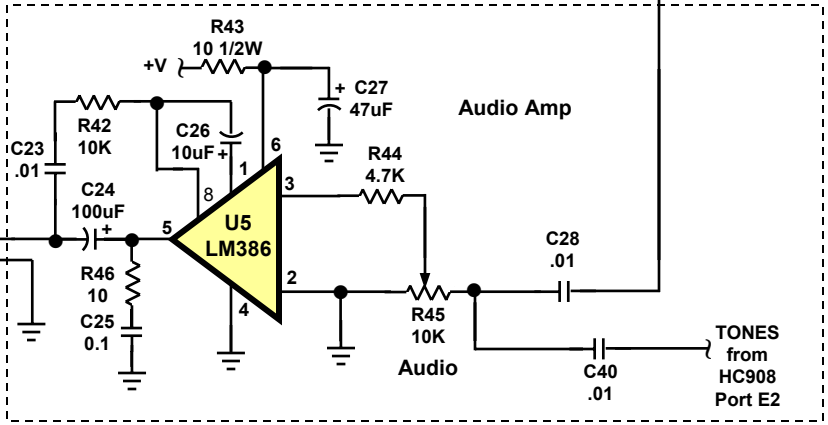
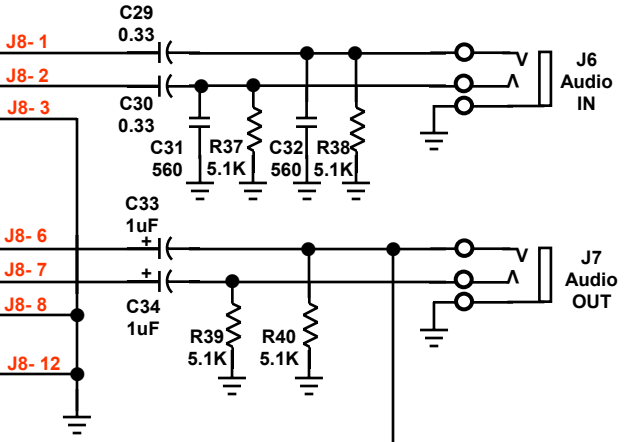
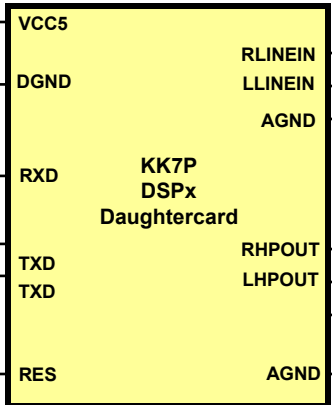
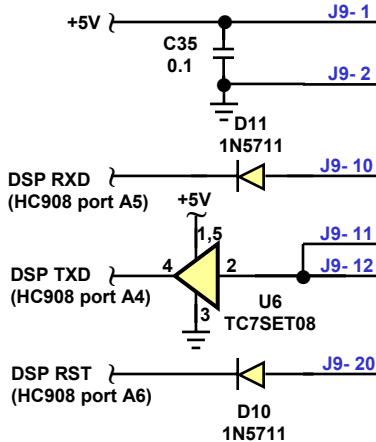
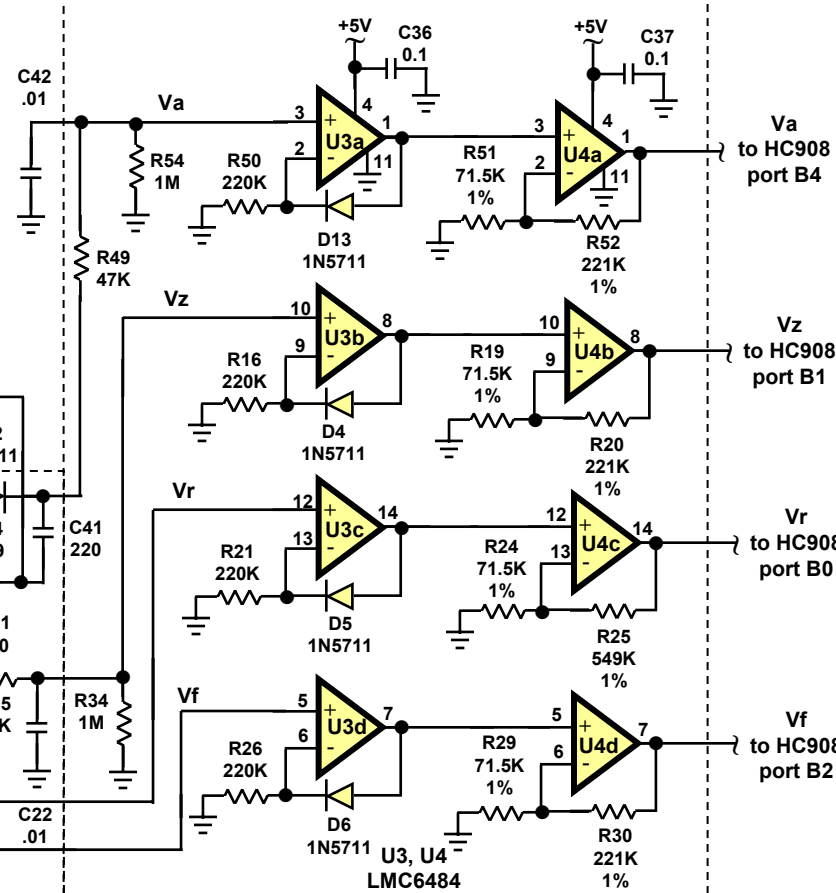



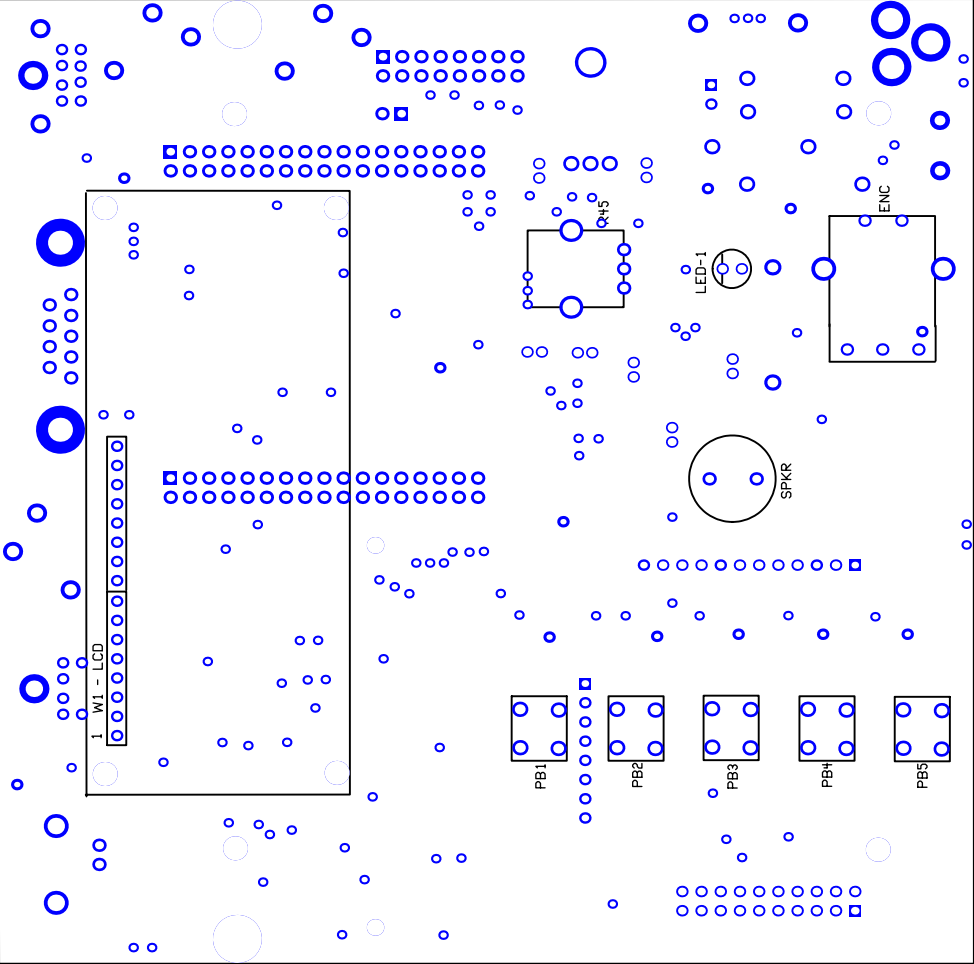

1 W1 - LCD

PB1

PB2

PB3

PB4

PB5

LED-1

SPKR

ENC

## APPENDIX D: Completed PC Board Assembly

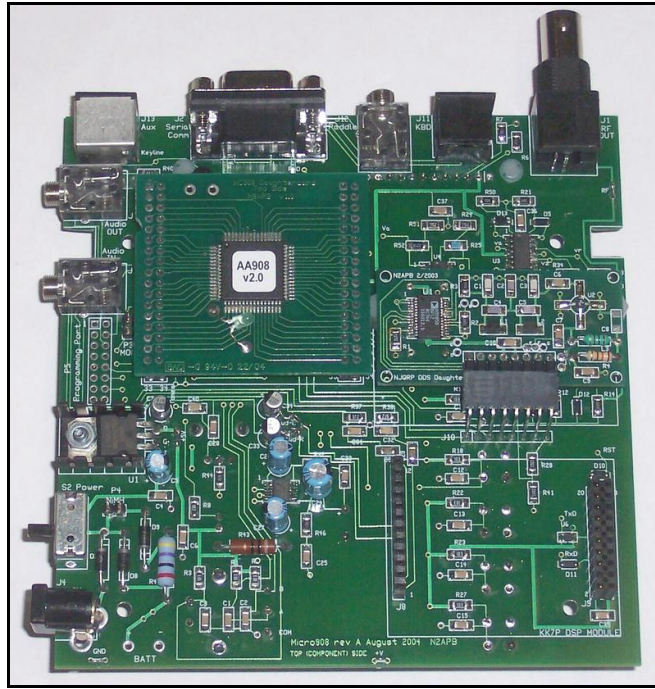

Top/Component Side

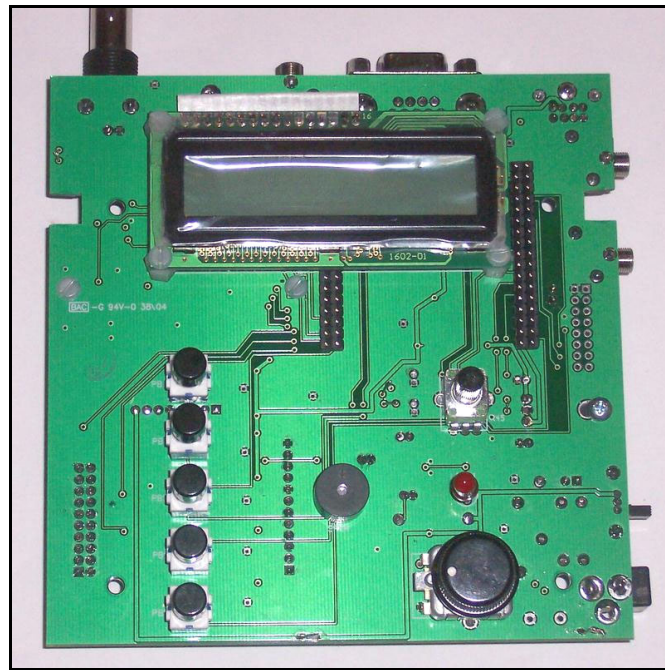

Bottom/Controls Side

APPENDIX E: Mechanical Assembly

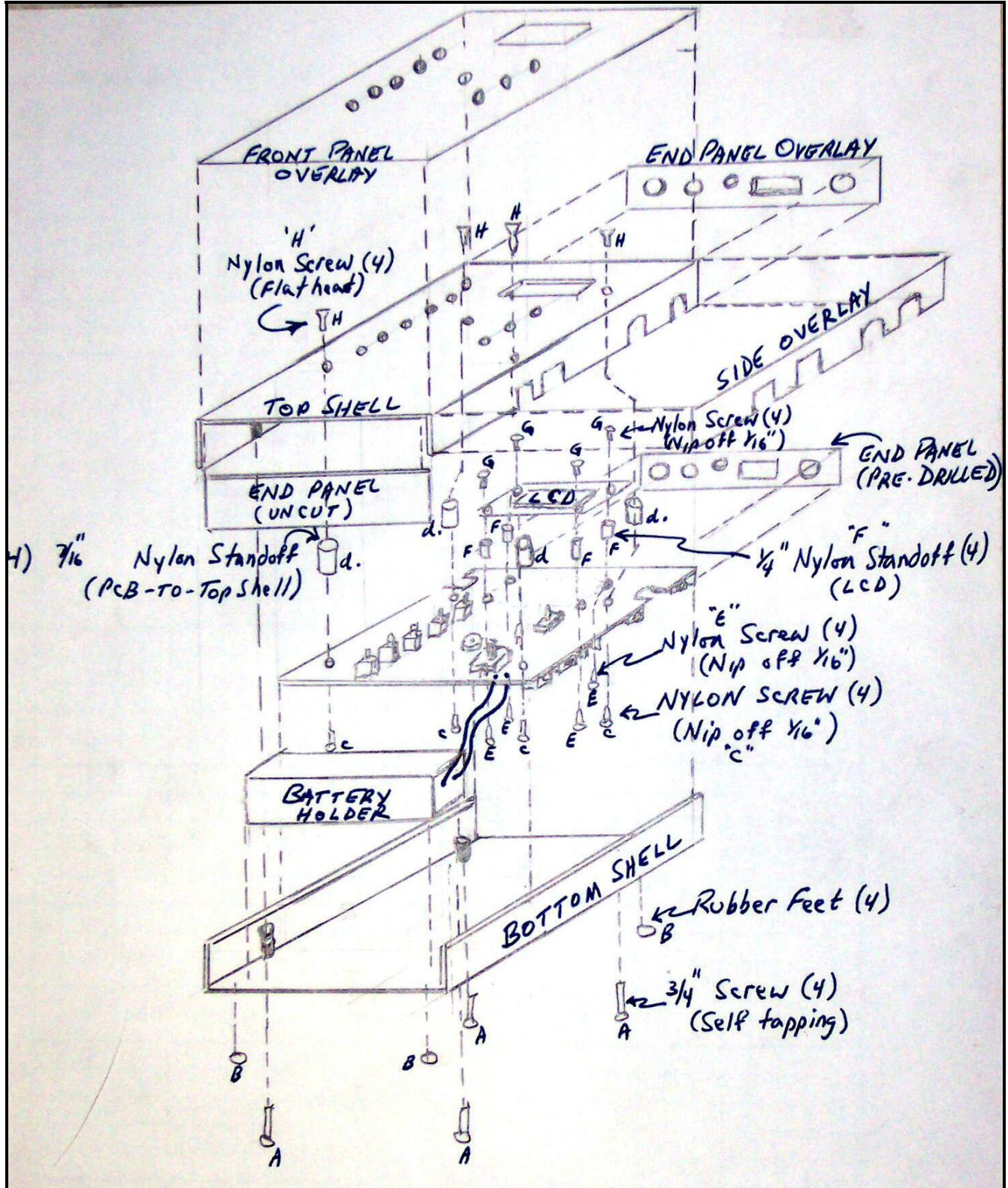

# Micro908 "Antenna Analyst"

## Quick Reference Sheet

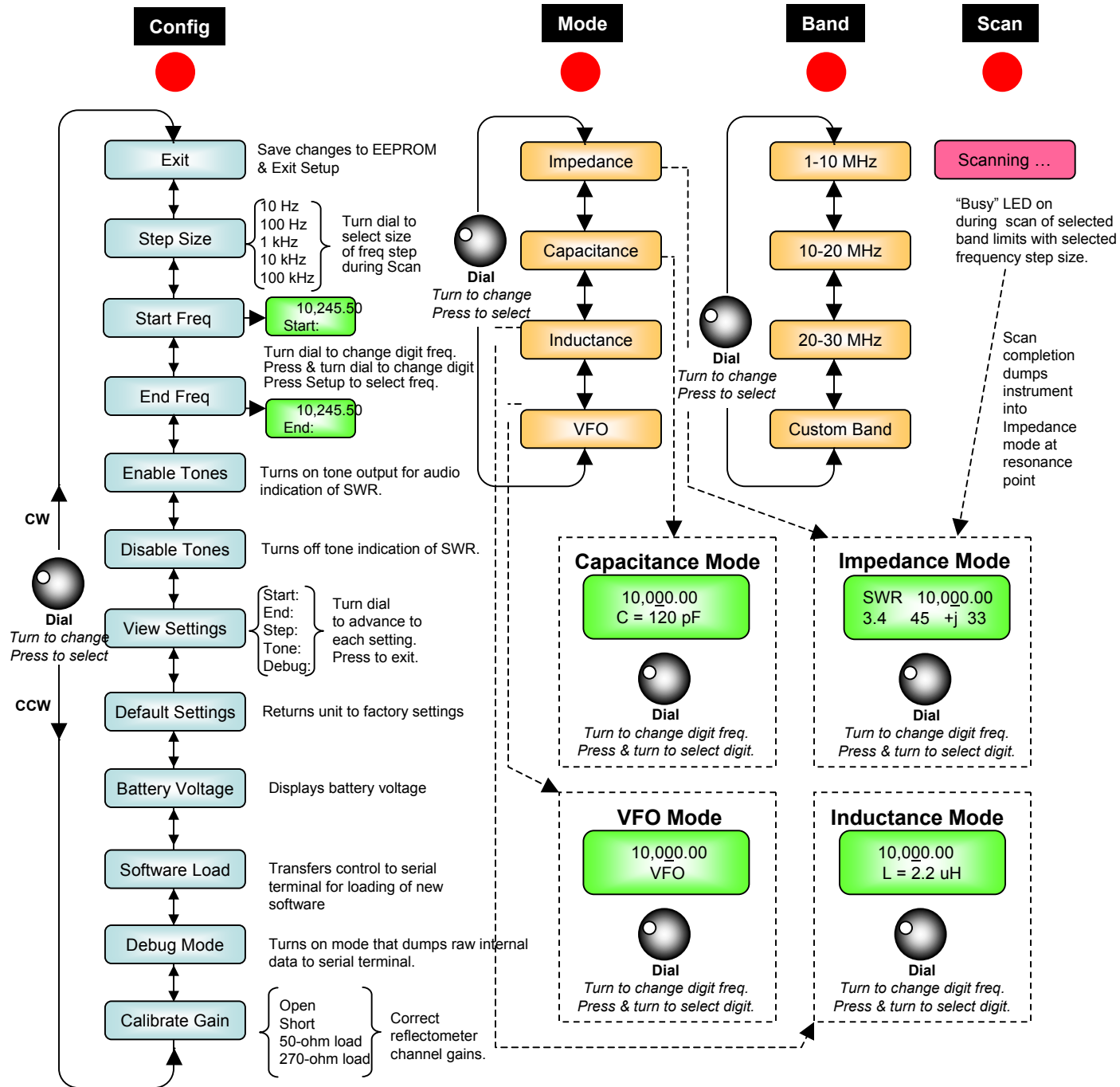

## APPENDIX G

### Loading New Software into the Micro908

This appendix overviews a way the user can load an updated software program into the Micro908, as provided on the project's Internet web site.

#### BACKGROUND

Increasingly today, microcontrolled projects have an ability to be "field updated" with new capabilities and software updates made available by the designer. So instead of needing to send your instrument back for re-programming to get these new features, you can now simply download the program update from the Internet and send it to the Micro908 and the instrument automatically updates its internal memory with the new program. What a great way to keep your project completely up to date with the latest features!

#### PC REQUIREMENTS

- Windows 95, Windows 98, Windows 2000, and Windows XP.
- Works with computers ranging from 33 MHz Intel 486 processors up to 2.4 GHz P4 processors.
- An available RS-232 serial port. (USB-to-RS232 adaptors may work for those computers having only USB-based serial ports.)
- A dumb terminal emulator program, such as TeraTerm (provided on the Micro908 Resource CDROM.)

#### USAGE

1. Download the latest Micro908 software from the project website located at <http://www.amqrp.org/kits/micro908> . Save the S19 file in a known location on your PC (e.g., your desktop folder.) The S19 file is the file with the ".s19" extension to its filename. This is a text representation of the binary image to be loaded onto the Micro908.
2. Connect your Micro908 to the PC using a standard, straight-through male-female DB9-type serial cable. (Do not use a null modem cable that swaps pins 2 and 3 from end-to-end.)
3. Start up the TeraTerm program on your PC. If not already set up, configure the communications as 9600 8N1, no flow control (in the **Setup** → **Serial Port** menu) , and be certain to have the line delay set to at least "20ms/line". Make sure that you have TeraTerm configured to be using the active serial port in your PC. Be certain that no other program has control of the serial port – e.g., if your Palm HotSync program is running, as evidenced by its icon in the system tray in the lower right of the screen, you must quit that program by right-clicking the icon and select "exit".)
4. Issue the **Update Software** command on the Micro908, located as an option under the CONFIG menu. See the debug monitor program called "HCmon" display its sign-on message.
5. Type **C** to clear out memory. See the C character echoed to the screen and the HCmon> prompt displayed again.
6. Type **L** to load new program. See message "...waiting ..."
7. Pull down the **File** → **Send File** menu.
8. Navigate to where you saved the \*.s19 file
9. Once in the folder that contains AA\_908v4-0.s19 file, select that file and click the Open button. (Be careful to only load S19 files! If you mistakenly select any other file extension, it is highly likely that you'll mess up the bootstrap loader program.)
10. See line after line of ASCII data displayed in short one-second bursts. This will continue for about 2 minutes until the entire program has been sent to the Micro908 and flashed into its memory. **DO NOT INTERRUPT THIS PROCESS!!** When it is complete, the **HCmon** > command prompt will be displayed again.
11. Disconnect the serial cable and restart the Micro908 (i.e., turn the power off and on again) to start the newly-loaded program. You will observe the new version number presented in the sign-on display.

